

# ***SYLVANIA***

# **SERVICE MANUAL**

**27" COLOR TELEVISION**  
**6427CTC**

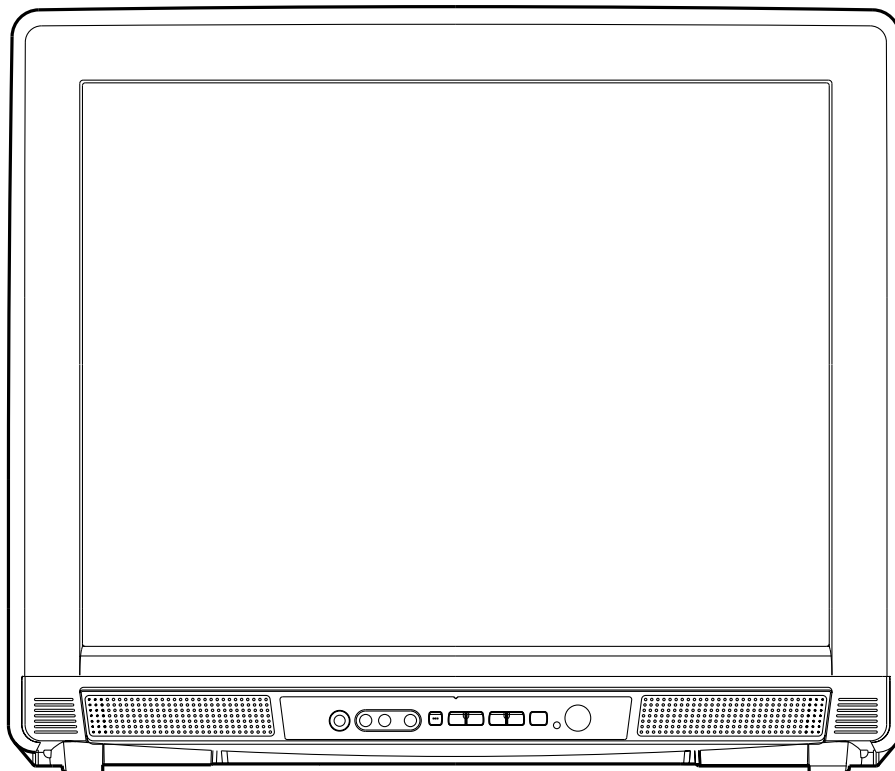

# IMPORTANT SAFETY NOTICE

Proper service and repair is important to the safe, reliable operation of all Funai Equipment. The service procedures recommended by Funai and described in this service manual are effective methods of performing service operations. Some of these service special tools should be used when and as recommended.

It is important to note that this service manual contains various CAUTIONS and NOTICES which should be carefully read in order to minimize the risk of personal injury to service personnel. The possibility exists that improper service methods may damage the equipment. It also is important to understand that these CAUTIONS and NOTICES ARE NOT EXHAUSTIVE. Funai could not possibly know, evaluate and advise the service trade of all conceivable ways in which service might be done or of the possible hazardous consequences of each way. Consequently, Funai has not undertaken any such broad evaluation. Accordingly, a servicer who uses a service procedure or tool which is not recommended by Funai must first use all precautions thoroughly so that neither his safety nor the safe operation of the equipment will be jeopardized by the service method selected.

## TABLE OF CONTENTS

Specifications .....	1-1	CBA Views and Test Points.....	7-11
Important Safety Precautions.....	2-1	Wave Forms .....	8-1
Standard Notes for Servicing .....	3-1	Wiring Diagram.....	9-1
Disassembly Instructions .....	4-1	IC Pin Function .....	10-1
Electrical Adjustment Instructions .....	5-1	Cabinet Exploded View .....	11-1
Block Diagram.....	6-1	Packing Exploded View .....	11-3
Schematic Diagram / CBA's and Test Points .....	7-1	Mechanical Parts List .....	12-1
Schematic Diagram .....	7-3	Electrical Parts List.....	13-1

# SPECIFICATIONS

## <TUNER>

ANT. Input ----- 75ohm Unbal., F type  
 Reference Level ----- 20Vp-p (CRT Green Cathode)  
 Test Input Signal ----- 400Hz 30% modulation

Description	Condition	Unit	Nominal	Limit
1. Intermediate Freq.	Picture	MHz	45.75	—
	Sound	MHz	41.25	—
2. Peak Picture Sens	VHF	dB $\mu$ v	15	30
	CATV	dB $\mu$ v	15	30
	UHF	dB $\mu$ v	15	40
3. AFT Pull In Range (10mV input)	—	MHz	$\pm$ 2.0	$\pm$ 0.7

## <DEFLECTION>

Description	Condition	Unit	Nominal	Limit
1. Deflection Freq.	Horizontal	KHz	15.734	—
	Vertical	Hz	60	—
2. Linearity	Horizontal	%	—	$\pm$ 15
	Vertical	%	—	$\pm$ 10
3. Over Scan	—	%	10	—
4. High Voltage	—	KV	29	—

## <VIDEO & CHROMA>

Description	Condition	Unit	Nominal	Limit
1. Misconvergence	Center	mm	—	0.4
	Side	mm	—	1.5
	Corner	mm	—	2.1
2. Brightness	APL 100%	Ft-L	25	15
3. Color Temperature	—	$^{\circ}$ K	9200 $^{\circ}$ K	—
4. Resolution	Horizontal	Line	250	—
	Vertical	Line	300	—

## <AUDIO>

All items are measured across 8 $\Omega$  load at speaker output terminal.

Description	Condition	Unit	Nominal	Limit
1. Audio Output Power	10% THD	W	1	0.8
2. Audio Distortion (w/LPF)	500mW	%	2	7
3. Audio Freq. Response	-3dB	Hz	70~11K	—

### Note:

Nominal specifications represent the design specifications. All units should be able to approximate these. Some will exceed and some may drop slightly below these specifications. Limit specifications represent the absolute worst condition that still might be considered acceptable. In no case should a unit fail to meet limit specifications.

# IMPORTANT SAFETY PRECAUTIONS

Prior to shipment from the factory, our products are strictly inspected for recognized product safety and electrical codes of the countries in which they are to be sold. However, in order to maintain such compliance, it is equally important to implement the following precautions when a set is being serviced.

## Safety Precautions for TV Circuit

1. **Before returning an instrument to the customer**, always make a safety check of the entire instrument, including, but not limited to, the following items:
  - a. Be sure that no built-in protective devices are defective and have been defeated during servicing. (1) Protective shields are provided on this chassis to protect both the technician and the customer. Correctly replace all missing protective shields, including any removed for servicing convenience. (2) When reinstalling the chassis and/or other assembly in the cabinet, be sure to put back in place all protective devices, including but not limited to, nonmetallic control knobs, insulating fishpapers, adjustment and compartment covers/shields, and isolation resistor/capacitor networks. **Do not operate this instrument or permit it to be operated without all protective devices correctly installed and functioning. Servicers who defeat safety features or fail to perform safety checks may be liable for any resulting damage.**
  - b. Be sure that there are no cabinet openings through which an adult or child might be able to insert their fingers and contact a hazardous voltage. Such openings include, but are not limited to, (1) spacing between the picture tube and the cabinet mask, (2) excessively wide cabinet ventilation slots, and (3) an improperly fitted and/or incorrectly secured cabinet back cover.
  - c. **Antenna Cold Check** - With the instrument AC plug removed from any AC source, connect an electrical jumper across the two AC plug prongs. Place the instrument AC switch in the on position. Connect one lead of an ohmmeter to the AC plug prongs tied together and touch the other ohmmeter lead in turn to each tuner antenna input exposed terminal screw and, if applicable, to the coaxial connector. If the measured resistance is less than 1.0 megohm or greater than 5.2 megohm, an abnormality exists that must be corrected before the instrument is returned to the customer. Repeat this test with the instrument AC switch in the off position.
  - d. **Leakage Current Hot Check** - With the instrument completely reassembled, plug the AC line cord directly into a 120V AC outlet. (Do not use an isolation transformer during this test.) Use a leak-

age current tester or a metering system that complies with American National Standards Institute (ANSI) C101.1 Leakage Current for Appliances and Underwriters Laboratories (UL) 1410, (50.7). With the instrument AC switch first in the on position and then in the off position, measure from a known earth ground (metal water pipe, conduit, etc.) to all exposed metal parts of the instrument (antennas, handle brackets, metal cabinet, screw heads, metallic overlays, control shafts, etc.), especially any exposed metal parts that offer an electrical return path to the chassis. Any current measured must not exceed 0.5 milli-ampere. Reverse the instrument power cord plug in the outlet and repeat the test.

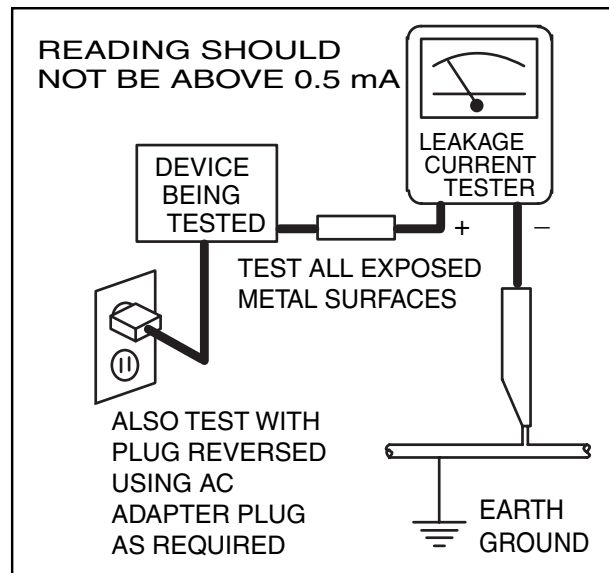

**ANY MEASUREMENTS NOT WITHIN THE LIMITS SPECIFIED HEREIN INDICATE A POTENTIAL SHOCK HAZARD THAT MUST BE ELIMINATED BEFORE RETURNING THE INSTRUMENT TO THE CUSTOMER OR BEFORE CONNECTING THE ANTENNA OR ACCESSORIES.**

- e. **X-Radiation and High Voltage Limits** - Because the picture tube is the primary potential source of X-radiation in solid-state TV receivers, it is specially constructed to prohibit X-radiation emissions. For continued X-radiation protection, the replacement picture tube must be the same type as the original. Also, because the picture tube shields and mounting hardware perform an X-radiation protection function, they must be correctly in place. High voltage must be measured each time servic-

ing is performed that involves B+, horizontal deflection or high voltage. Correct operation of the X-radiation protection circuits also must be reconfirmed each time they are serviced. (X-radiation protection circuits also may be called "horizontal disable" or "hold down.") Read and apply the high voltage limits and, if the chassis is so equipped, the X-radiation protection circuit specifications given on instrument labels and in the Product Safety & X-Radiation Warning note on the service data chassis schematic. High voltage is maintained within specified limits by close tolerance safety-related components/adjustments in the high-voltage circuit. If high voltage exceeds specified limits, check each component specified on the chassis schematic and take corrective action.

2. Read and comply with all caution and safety-related notes on or inside the receiver cabinet, on the receiver chassis, or on the picture tube.

3. **Design Alteration Warning** - Do not alter or add to the mechanical or electrical design of this TV receiver. Design alterations and additions, including, but not limited to circuit modifications and the addition of items such as auxiliary audio and/or video output connections, might alter the safety characteristics of this receiver and create a hazard to the user. Any design alterations or additions will void the manufacturer's warranty and may make you, the servicer, responsible for personal injury or property damage resulting therefrom.

4. **Picture Tube Implosion Protection Warning** - The picture tube in this receiver employs integral implosion protection. For continued implosion protection, replace the picture tube only with one of the same type number. Do not remove, install, or otherwise handle the picture tube in any manner without first putting on shatterproof goggles equipped with side shields. People not so equipped must be kept safely away while picture tubes are handled. Keep the picture tube away from your body. Do not handle the picture tube by its neck. Some "in-line" picture tubes are equipped with a permanently attached deflection yoke; because of potential hazard, do not try to remove such "permanently attached" yokes from the picture tube.

5. **Hot Chassis Warning** -

a. Some TV receiver chassis are electrically connected directly to one conductor of the AC power cord and maybe safety-serviced without an isolation transformer only if the AC power plug is inserted so that the chassis is connected to the ground side of the AC power source. To confirm that the AC power plug is inserted correctly, with an AC voltmeter, measure between the chassis and a known

earth ground. If a voltage reading in excess of 1.0V is obtained, remove and reinsert the AC power plug in the opposite polarity and again measure the voltage potential between the chassis and a known earth ground.

b. Some TV receiver chassis normally have 85V AC(RMS) between chassis and earth ground regardless of the AC plug polarity. This chassis can be safety-serviced only with an isolation transformer inserted in the power line between the receiver and the AC power source, for both personnel and test equipment protection.

c. Some TV receiver chassis have a secondary ground system in addition to the main chassis ground. This secondary ground system is not isolated from the AC power line. The two ground systems are electrically separated by insulation material that must not be defeated or altered.

6. Observe original lead dress. Take extra care to assure correct lead dress in the following areas:a. near sharp edges,b. near thermally hot parts-be sure that leads and components do not touch thermally hot parts,c. the AC supply,d. high voltage, and,e. antenna wiring. Always inspect in all areas for pinched, out of place, or frayed wiring. Check AC power cord for damage.

7. Components, parts, and/or wiring that appear to have overheated or are otherwise damaged should be replaced with components, parts, or wiring that meet original specifications. Additionally, determine the cause of overheating and/or damage and, if necessary, take corrective action to remove any potential safety hazard.

8. **Product Safety Notice** - Some electrical and mechanical parts have special safety-related characteristics which are often not evident from visual inspection, nor can the protection they give necessarily be obtained by replacing them with components rated for higher voltage, wattage, etc.. Parts that have special safety characteristics are identified by a (▲) on schematics and in parts lists. Use of a substitute replacement that does not have the same safety characteristics as the recommended replacement part might create shock, fire, and/or other hazards. The product's safety is under review continuously and new instructions are issued whenever appropriate. Prior to shipment from the factory, our products are strictly inspected to confirm they comply with the recognized product safety and electrical codes of the countries in which they are to be sold. However, in order to maintain such compliance, it is equally important to implement the following precautions when a set is being serviced.

## Precautions during Servicing

**A.** Parts identified by the ( ▲ ) symbol are critical for safety.

Replace only with part number specified.

**B.** In addition to safety, other parts and assemblies are specified for conformance with regulations applying to spurious radiation. These must also be replaced only with specified replacements.

Examples: RF converters, RF cables, noise blocking capacitors, and noise blocking filters, etc.

**C.** Use specified internal wiring. Note especially:

- 1) Wires covered with PVC tubing
- 2) Double insulated wires
- 3) High voltage leads

**D.** Use specified insulating materials for hazardous live parts. Note especially:

- 1) Insulation Tape
- 2) PVC tubing
- 3) Spacers
- 4) Insulators for transistors.

**E.** When replacing AC primary side components (transformers, power cord, etc.), wrap ends of wires securely about the terminals before soldering.

**F.** Observe that the wires do not contact heat producing parts (heatsinks, oxide metal film resistors, fusible resistors, etc.)

**G.** Check that replaced wires do not contact sharp edged or pointed parts.

**H.** When a power cord has been replaced, check that 5~6 kg of force in any direction will not loosen it.

**I.** Also check areas surrounding repaired locations.

**J.** Use care that foreign objects (screws, solder droplets, etc.) do not remain inside the set.

**K.** Crimp type wire connector

The power transformer uses crimp type connectors which connect the power cord and the primary side of the transformer. When replacing the transformer, follow these steps carefully and precisely to prevent shock hazards.

Replacement procedure

- 1) Remove the old connector by cutting the wires at a point close to the connector.  
Important: Do not re-use a connector (discard it).
- 2) Strip about 15 mm of the insulation from the ends of the wires. If the wires are stranded, twist the strands to avoid frayed conductors.

3) Align the lengths of the wires to be connected. Insert the wires fully into the connector.

4) Use the crimping tool to crimp the metal sleeve at the center position. Be sure to crimp fully to the complete closure of the tool.

**L.** When connecting or disconnecting the internal connectors, first, disconnect the AC plug from the AC supply outlet.

## Safety Check after Servicing

Examine the area surrounding the repaired location for damage or deterioration. Observe that screws, parts and wires have been returned to original positions. Afterwards, perform the following tests and confirm the specified values in order to verify compliance with safety standards.

### 1. Clearance Distance

When replacing primary circuit components, confirm specified clearance distance ( $d$ ) and ( $d'$ ) between soldered terminals, and between terminals and surrounding metallic parts. (See Fig. 1)

**Table 1 : Ratings for selected area**

AC Line Voltage	Region	Clearance Distance ( $d$ ) ( $d'$ )
110 to 130 V	USA or CANADA	$\geq 3.2$ mm (0.126 inches)

**Note:** This table is unofficial and for reference only. Be sure to confirm the precise values.

### 2. Leakage Current Test

Confirm the specified (or lower) leakage current between B (earth ground, power cord plug prongs) and externally exposed accessible parts (RF terminals, antenna terminals, video and audio input and output terminals, microphone jacks, earphone jacks, etc.) is lower than or equal to the specified value in the table below.

#### Measuring Method : (Power ON)

Insert load Z between B (earth ground, power cord plug prongs) and exposed accessible parts. Use an AC voltmeter to measure across both terminals of load Z. See Fig. 2 and following table.

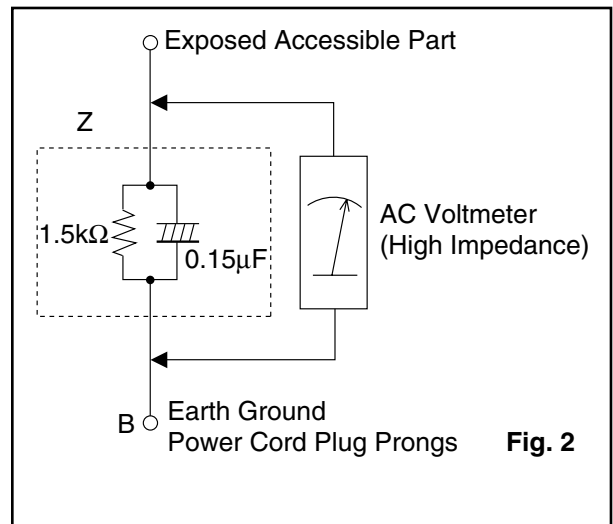
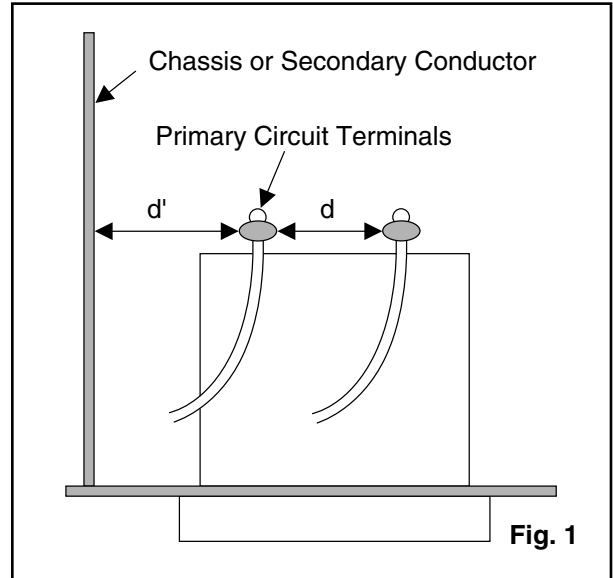

**Table 2 : Leakage current ratings for selected areas**

AC Line Voltage	Region	Load Z	Leakage Current (i)	Earth Ground (B) to:
110 to 130 V	USA	$0.15\mu F$ CAP. & $1.5k\Omega$ RES. connected in parallel	$i \leq 0.5$ mA rms	Exposed accessible parts

**Note:** This table is unofficial and for reference only. Be sure to confirm the precise values.

# STANDARD NOTES FOR SERVICING

## Circuit Board Indications

- a. The output pin of the 3 pin Regulator ICs is indicated as shown.

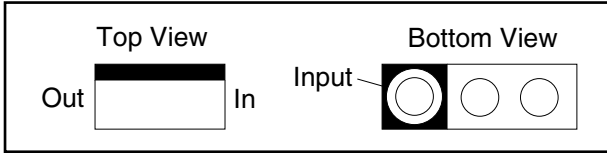

- b. For other ICs, pin 1 and every fifth pin are indicated as shown.

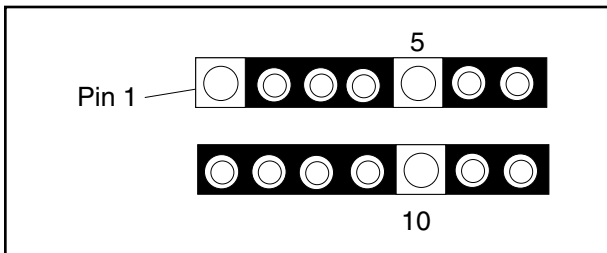

- c. The 1st pin of every male connector is indicated as shown.

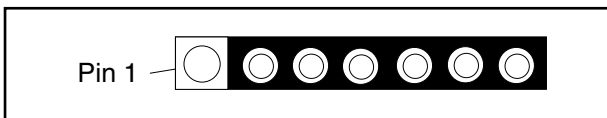

## How to Remove / Install Flat Pack-IC

### 1. Removal

#### With Hot-Air Flat Pack-IC Desoldering Machine:

- (1) Prepare the hot-air flat pack-IC desoldering machine, then apply hot air to the Flat Pack-IC (about 5 to 6 seconds). (Fig. S-1-1)

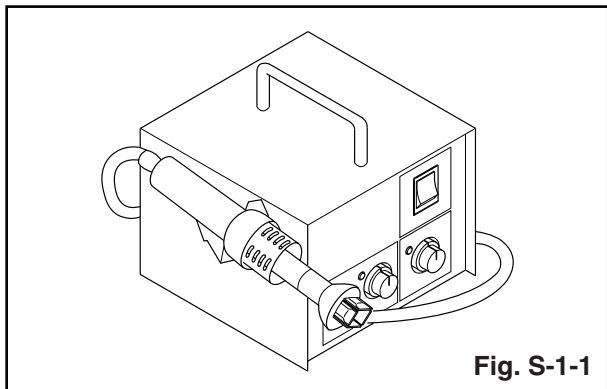

Fig. S-1-1

- (2) Remove the flat pack-IC with tweezers while applying the hot air.  
 (3) Bottom of the flat pack-IC is fixed with glue to the CBA; when removing entire flat pack-IC, first apply soldering iron to center of the flat pack-IC and heat up. Then remove (glue will be melted). (Fig. S-1-6)  
 (4) Release the flat pack-IC from the CBA using tweezers. (Fig. S-1-6)

### Caution:

1. Do not supply hot air to the chip parts around the flat pack-IC for over 6 seconds because damage to the chip parts may occur. Put masking tape around the flat pack-IC to protect other parts from damage. (Fig. S-1-2)
2. The flat pack-IC on the CBA is affixed with glue, so be careful not to break or damage the foil of each pin or the solder lands under the IC when removing it.

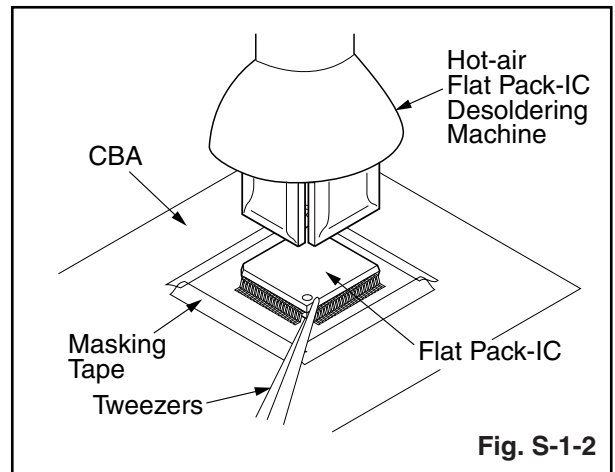
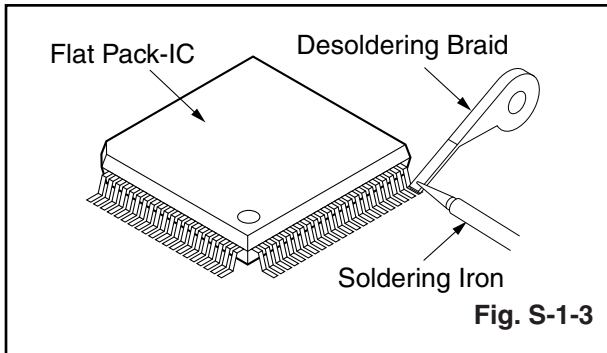

Fig. S-1-2



### With Soldering Iron:

- (1) Using desoldering braid, remove the solder from all pins of the flat pack-IC. When you use solder flux which is applied to all pins of the flat pack-IC, you can remove it easily. (Fig. S-1-3)



- (2) Lift each lead of the flat pack-IC upward one by one, using a sharp pin or wire to which solder will not adhere (iron wire). When heating the pins, use a fine tip soldering iron or a hot air desoldering machine. (Fig. S-1-4)

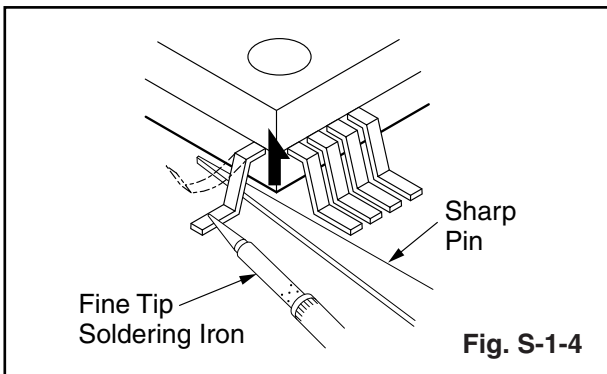

- (3) Bottom of the flat pack-IC is fixed with glue to the CBA; when removing entire flat pack-IC, first apply soldering iron to center of the flat pack-IC and heat up. Then remove (glue will be melted). (Fig. S-1-6)
- (4) Release the flat pack-IC from the CBA using tweezers. (Fig. S-1-6)

### With Iron Wire:

- (1) Using desoldering braid, remove the solder from all pins of the flat pack-IC. When you use solder flux which is applied to all pins of the flat pack-IC, you can remove it easily. (Fig. S-1-3)
- (2) Affix the wire to a workbench or solid mounting point, as shown in Fig. S-1-5.
- (3) While heating the pins using a fine tip soldering iron or hot air blower, pull up the wire as the solder melts so as to lift the IC leads from the CBA contact pads as shown in Fig. S-1-5.
- (4) Bottom of the flat pack-IC is fixed with glue to the CBA; when removing entire flat pack-IC, first apply

- soldering iron to center of the flat pack-IC and heat up. Then remove (glue will be melted). (Fig. S-1-6)
- (5) Release the flat pack-IC from the CBA using tweezers. (Fig. S-1-6)

### Note:

When using a soldering iron, care must be taken to ensure that the flat pack-IC is not being held by glue. When the flat pack-IC is removed from the CBA, handle it gently because it may be damaged if force is applied.

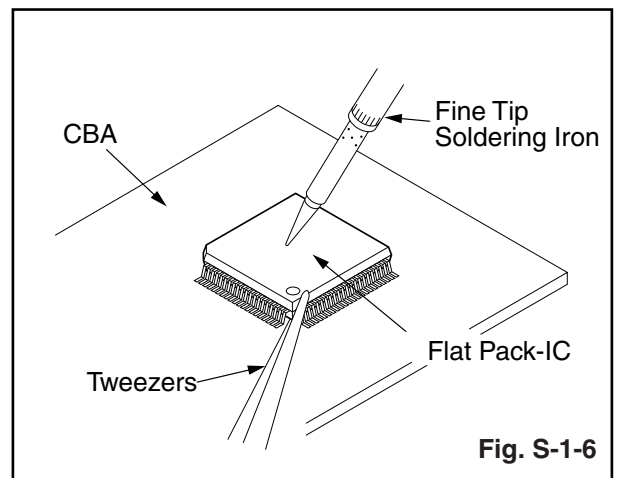
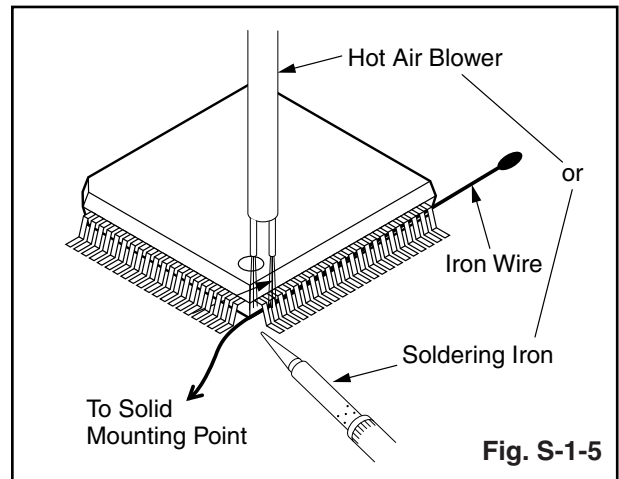

## 2. Installation

- (1) Using desoldering braid, remove the solder from the foil of each pin of the flat pack-IC on the CBA so you can install a replacement flat pack-IC more easily.
- (2) The "●" mark on the flat pack-IC indicates pin 1. (See Fig. S-1-7.) Be sure this mark matches the 1 on the PCB when positioning for installation. Then pre-solder the four corners of the flat pack-IC. (See Fig. S-1-8.)
- (3) Solder all pins of the flat pack-IC. Be sure that none of the pins have solder bridges.

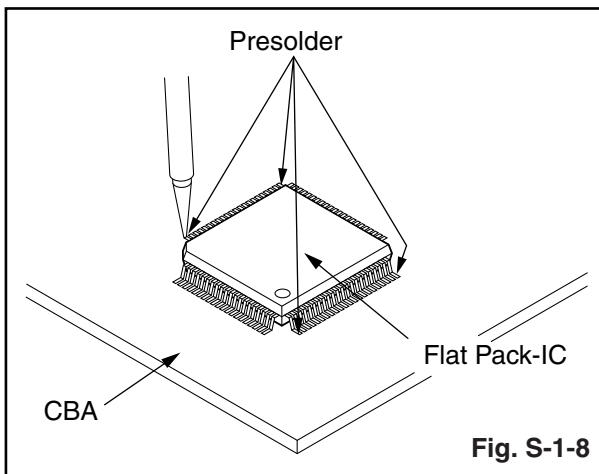
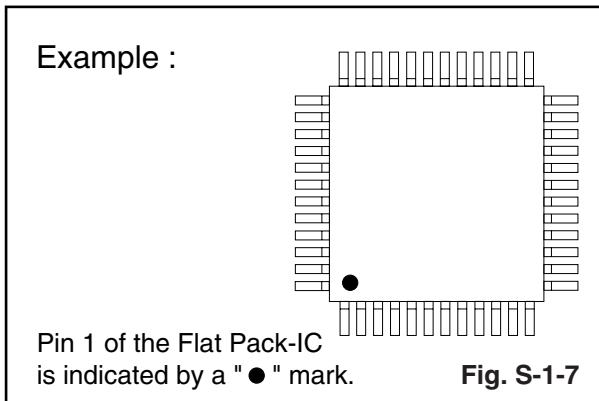

## Instructions for Handling Semiconductors

Electrostatic breakdown of the semiconductors may occur due to a potential difference caused by electrostatic charge during unpacking or repair work.

### 1. Ground for Human Body

Be sure to wear a grounding band ( $1M\Omega$ ) that is properly grounded to remove any static electricity that may be charged on the body.

### 2. Ground for Workbench

Be sure to place a conductive sheet or copper plate with proper grounding ( $1M\Omega$ ) on the workbench or other surface, where the semiconductors are to be placed. Because the static electricity charge on clothing will not escape through the body grounding band, be careful to avoid contacting semiconductors with your clothing.

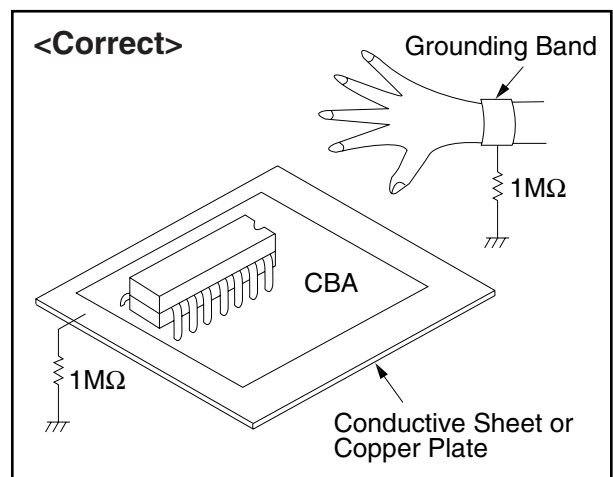
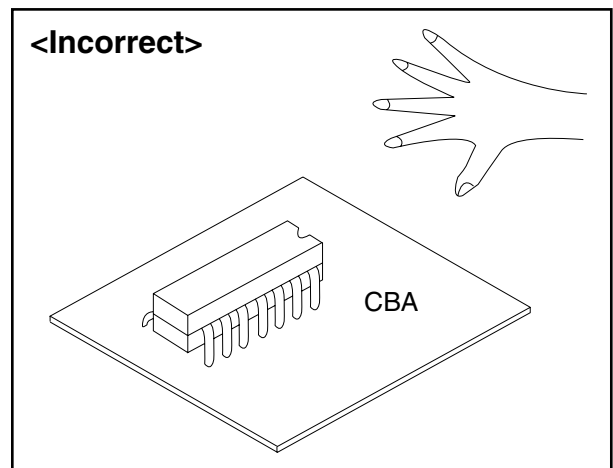

# CABINET DISASSEMBLY INSTRUCTIONS

## 1. Disassembly Flowchart

This flowchart indicates the disassembly steps for the cabinet parts, and the CBA in order to gain access to item(s) to be serviced. When reassembling, follow the steps in reverse order. Bend, route and dress the cables as they were.

### Caution !

When removing the CRT, be sure to discharge the Anode Lead of the CRT with the CRT Ground Wire before removing the Anode Cap.

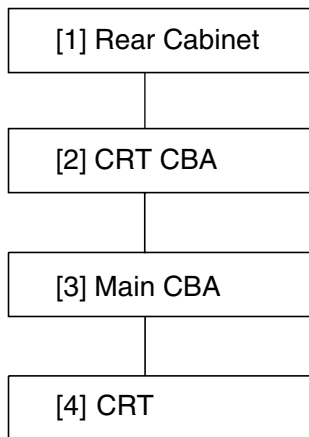

## 2. Disassembly Method

Step/ Loc. No.	Part	Removal		
		Fig. No	Remove/*unlock/ release/unplug/ unclamp/desolder	Note
[1]	Rear Cabinet	1,2	7(S-1), 2(S-2), 1(S-4)	1
[2]	CRT CBA	4,5	CN501	2
[3]	Main CBA	3,5	CN571	3
[4]	CRT	4	4(S-3), Anode Cap	4

↓            ↓            ↓            ↓            ↓  
 (1)        (2)        (3)        (4)        (5)

### Note :

- (1) Order of steps in procedure. When reassembling, follow the steps in reverse order. These numbers are also used as the Identification (location) No. of parts in figures.
- (2) Parts to be removed or installed.
- (3) Fig. No. showing procedure of part location
- (4) Identification of part to be removed, unhooked, unlocked, released, unplugged, unclamped, or desoldered.  
S=Screw, P=Spring, L=Locking Tab, CN=Connector, \*=Unhook, Unlock, Release, Unplug, or Desolder  
2(S-2) = two Screws (S-2)
- (5) Refer to the following "Reference Notes in the Table."

### Reference Notes in the Table

1. Removal of the Rear Cabinet. Remove screws 7(S-1), 2(S-2) and 1(S-4) then slide the Rear Cabinet backward.
2. Removal of the CRT CBA. Disconnect CN501 then pull the CRT CBA backward.
3. Removal of the Main CBA. Disconnect CN571 on the Main CBA then slide the Main CBA backward.

### Caution !

Discharge the Anode Lead of the CRT with the CRT Ground Wire before removing the Anode Cap.

4. Removal of the CRT. Remove screws 4(S-3) and Anode Cap. then slide the CRT backward.

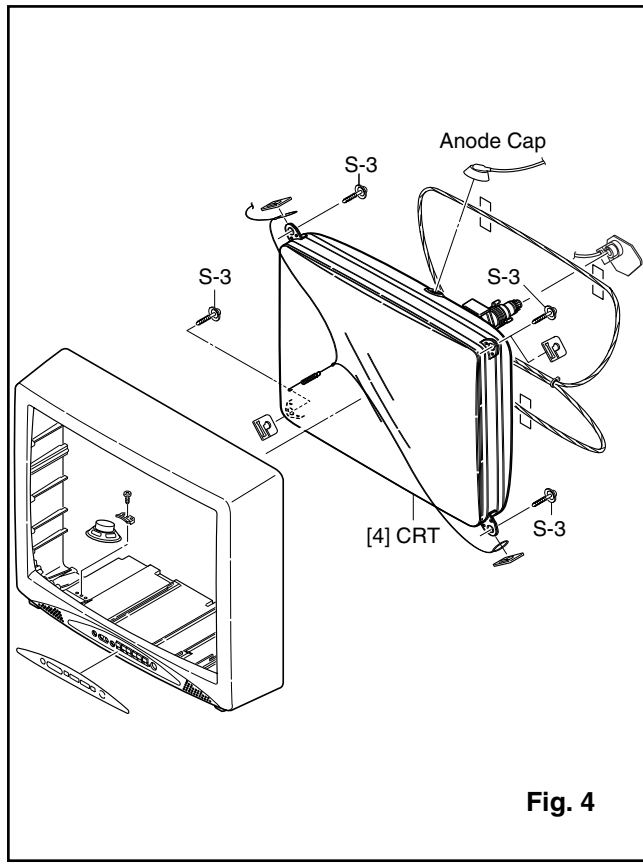
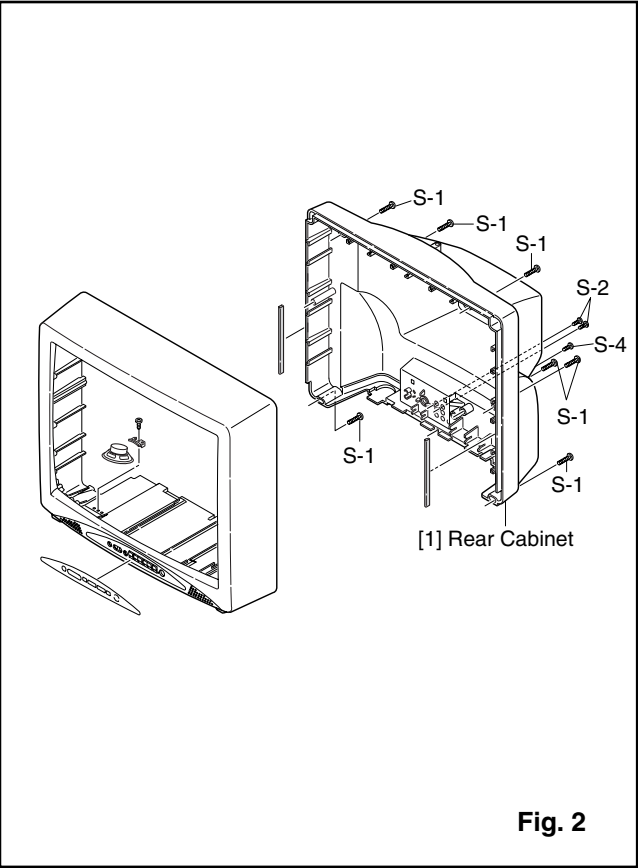
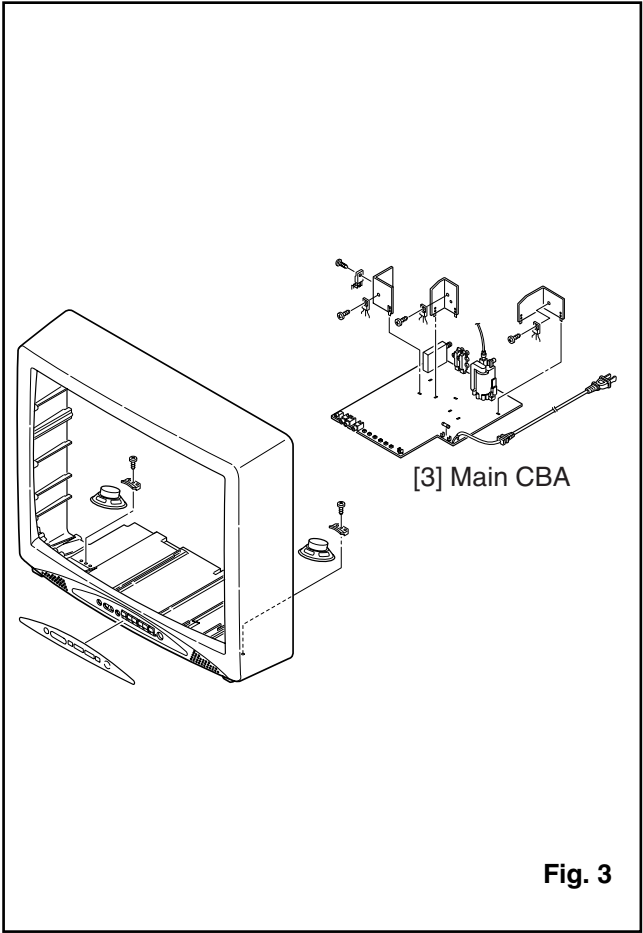
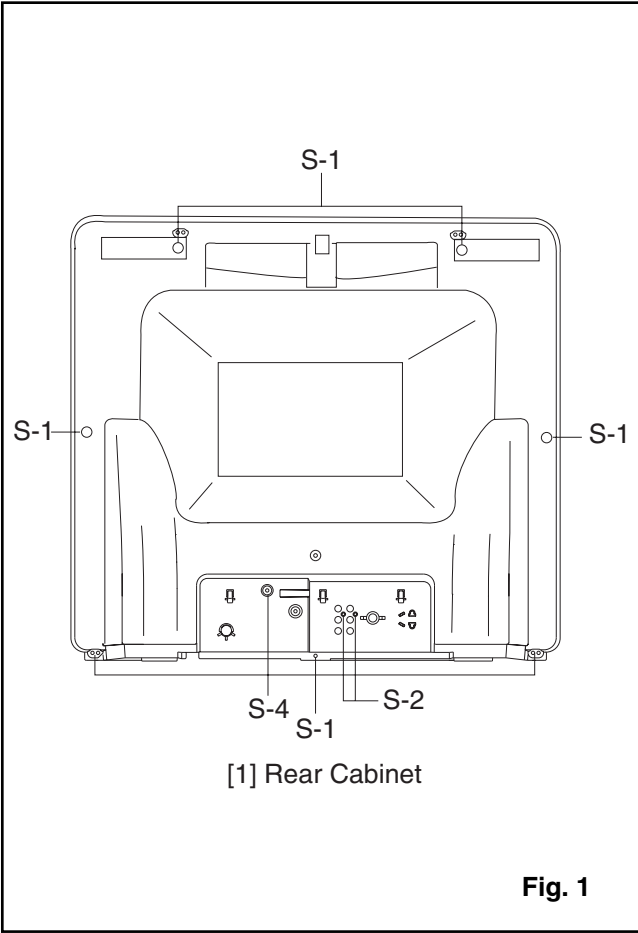

# TV Cable Wiring Diagram

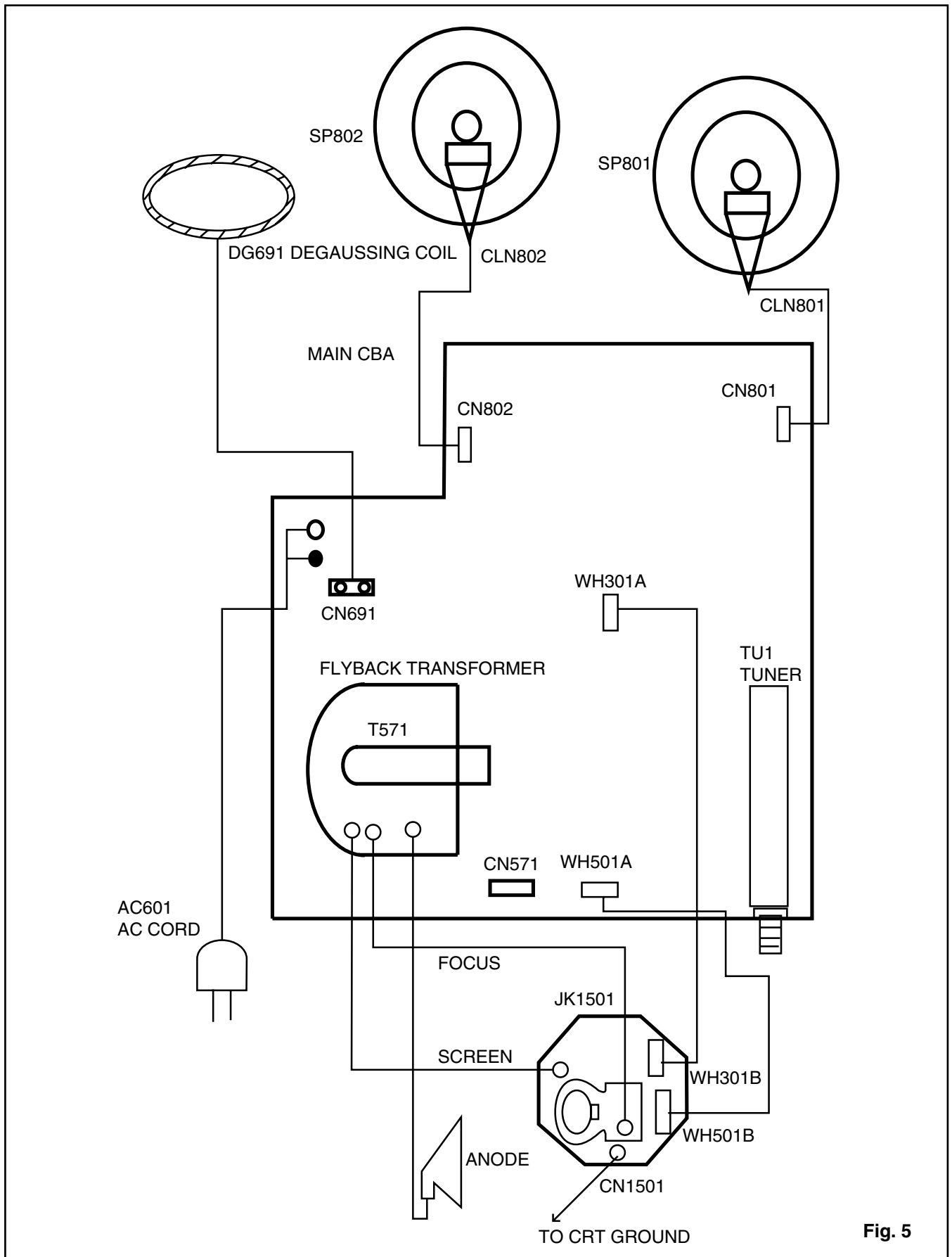

Fig. 5

# ELECTRICAL ADJUSTMENT INSTRUCTIONS

## General Note:

"CBA" is abbreviation for "Circuit Board Assembly".

## NOTE:

Electrical adjustments are required after replacing circuit components and certain mechanical parts. It is important to perform these adjustments only after all repairs and replacements have been completed.

Also, do not attempt these adjustments unless the proper equipment is available.

## Test Equipment Required

1. NTSC Pattern Generator (Color Bar W/White Window, Red Color, Dot Pattern, Gray Scale, Monoscope, Multi-Burst)
2. DC Voltmeter
3. Oscilloscope: Dual-trace with 10:1 probe, V-Range:0.001~50V/Div, F-Range:DC~AC-60MHz
4. Plastic Tip Driver
5. Remote control unit:Part No. N0127UD or N0132UD or N0105UD or N0108UD
6. DC power supply 13.2V/5A

## How to make Service remote control unit:

1. Prepare normal remote control unit. (Part No. N0127UD or N0132UD or N0105UD or N0108UD) Remove 3 Screws from the back lid. (Fig. 1-1)
2. Added J1 (Jumper Wire) to the remote control CBA. (Fig. 1-2)

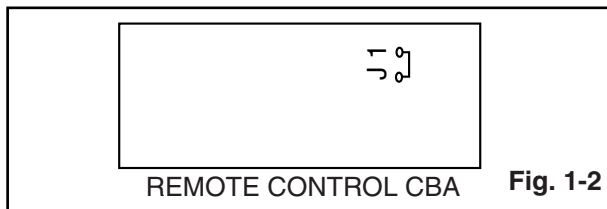
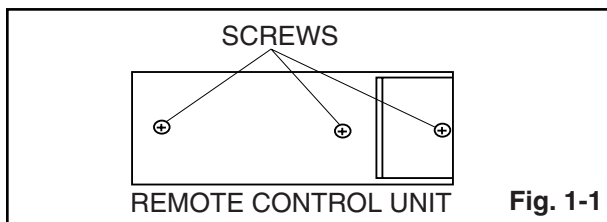

## 1. DC 120V Adjustment

**Purpose:** To obtain correct operation.

**Symptom of Misadjustment:** The picture is dark and the unit does not operate correctly.

Test Point	Adj. Point	Mode	Input
TP601(+120) TP300(GND)	VR661	---	---
Tape	M. EQ.	Spec.	
---	DC Voltmeter	+120±0.5V DC.	

**Note:**TP601, TP300(GND), VR661 --- Main CBA

1. Connect DC Volt Meter to TP601 and TP300(GND).
2. Adjust VR661 so that the voltage of TP601 becomes +120±0.5V DC.

## 2. Black Stretch Control Adjustment

**Purpose:** To show the fine black color.

**Symptom of Misadjustment:** Black color will not appear correctly.

**Note:** Use Service remote control unit.

1. Enter the Service mode. (See page 5-1)
2. Press " 6 " button on the Service remote control unit. " B-S " is indicated.
3. Press " CH ▲ / ▼ " buttons on the Service remote control unit so that display will change " OFF ", " 0 ", " 1 ", " 2 " and " 3 ". Then choose " B-S OFF ".
4. Press " 6 " button on the Service remote control unit. " B-S\*2 " is indicated.
5. Press " CH ▲ / ▼ " buttons on the Service remote control unit so that display will change " 0 ", " 1 ", " 2 " and " 3 ". Then choose " B-S\*2 0".
6. Turn the power off and on again. (Main power button on the TV unit.)

### 3-1. Setting for 7F and FRENCH data Values

#### General

1. Enter the Service mode. (See page 5-1)
2. Press " VOL ▼ " button on the Service remote control unit. Display changes " C/D ", " VCO ", " 7F ", " FRENCH ", " ACCESS CODE ", " STEREO ", " VIDEO TONE ", " FM-MODE ", and " AV-OUT " cyclically when " VOL ▼ " button is pressed.

#### 7F

1. Press " VOL ▼ " button on the Service remote control unit. Then select 7F display.
2. Press " CH ▲ / ▼ " buttons on the Service remote control unit. Then choose 7F=FF.

#### FRENCH

1. Press " VOL ▼ " button on the Service remote control unit. Then select FRENCH display.
2. Press " CH ▲ / ▼ " buttons on the Service remote control unit. Then choose FRENCH=ON.

ACCESS CODE ---- set to OFF

VIDEO TONE ---- set to OFF

FM-MODE ---- set to OFF

AV-OUT ---- set to ON

STEREO ---- set to ON

**Note:** C/D and VCO data values do not need to be adjusted at this moment.

### 3-2. Setting for CONTRAST, COLOR, TINT, V-TINT and SHARP data Values

#### General

1. Enter the Service mode. (See page 5-1)
2. Press " MENU " button on the Service remote control unit. Display changes " BRIGHT ", " CONTRAST ", " COLOR ", " TINT ", " V-TINT " and " SHARP " cyclically when " MENU " button is pressed.

#### CONTRAST (CNT)

1. Press " MENU " button on the Service remote control unit. Then select " CONTRAST " (CNT) display.
2. Press " CH ▲ / ▼ " buttons on the Service remote control unit so that the value of " CONTRAST " (CNT) becomes 84.

#### COLOR (CLR)

1. Press " MENU " button on the Service remote control unit. Then select " COLOR " (CLR) display.
2. Press " CH ▲ / ▼ " buttons on the Service remote control unit so that the value of " COLOR " (CLR) becomes 58.

#### TINT (TNT)

1. Press " MENU " button on the Service remote control unit. Then select " TINT " (TNT) display.
2. Press " CH ▲ / ▼ " buttons on the Service remote control unit so that the value of " TINT " (TNT) becomes 60.

#### V-TINT (V-TNT)

1. Press " MENU " button on the Service remote control unit. Then select " V-TINT " (V-TNT) display.
2. Press " CH ▲ / ▼ " buttons on the Service remote control unit so that the value of " V-TINT " (V-TNT) becomes 62.

#### SHARP (SHARP)

1. Press " MENU " button on the Service remote control unit. Then select " SHARP " (SHARP) display.
2. Press " CH ▲ / ▼ " buttons on the Service remote control unit and select " SHARP ON ".

**Note:** BRIGHT data value does not need to be adjusted at this moment.

## 4. H f<sub>0</sub> Adjustment

**Purpose:** To get correct horizontal frequency.

**Symptom of Misadjustment:** If H f<sub>0</sub> adjustment is in correct, sqew distortion will appear on the screen.

Test Point	Adj. Point	Mode	Input
TP302	CH ▲ / ▼ button ["H-ADJ"] MODE		---
Tape	M. EQ.	Spec.	
---	Frequency Counter	15.734kHz±300Hz	

**Note:** TP302 --- Main CBA

Use Service remote control unit.

1. Connect Frequency Counter to TP302 and ground.
2. Set the unit to the VIDEO mode which is located before CH2 and no input is necessary. Enter the Service mode. (See Page 5-1)
3. Operate the unit for at least 20 minutes.
4. Press " 2 " button on the Service remote control unit and select H-ADJ Mode. (By pressing " 2 " button the display will change from TV AGC to H-ADJ)
5. Press " CH ▲ / ▼ " button on the Service remote control unit so that the display will change " 0 " ~ " 7 ". At this moment, Choose display one of them from " 0 " ~ " 7 " when the Frequency Counter shows 15.734 kHz±300Hz or closer.
6. Turn the power off and on again. (Main Power button on the TV unit.)

## 5. VCO Adjustment

**Purpose:** To operate VCO correctly.

**Symptom of Misadjustment:** VCO does not work correctly and/or synchronization is faulty.

Test Point	Adj. Point	Mode	Input
---	---		No signal
<b>Tape</b>	<b>M. EQ.</b>	<b>Spec.</b>	
---	---	---	

**Note:** Use service remote control unit.

1. Disconnect the RF input and set the unit to Channel 4.
2. Enter the Service mode. (See Page 5-1)
3. Press " 3 " button on the Service remote control unit. The Auto VCO adjustment is started.
4. If the display color is changed from red to green, This adjustment is done.
5. Turn the Power off and on again. (Main power button on the TV unit.)

## 6. AGC Adjustment

**Purpose:** Set AGC (Auto Gain Control) Level.

**Symptom of Misadjustment:** AGC does not synchronize correctly when RF input level is too weak and picture distortion may occur if it is too strong.

Test Point	Adj. Point	Mode	Input
TP301	CH ▲ / ▼ buttons	RF	Color Bar 67.25MHz 60dBμV
<b>Tape</b>	<b>M. EQ.</b>	<b>Spec.</b>	
---	Pattern Generator DC Volt Meter	+2.5±0.1VDC or +2.8±0.1VDC or +2.7±0.1VDC by Tuner Type.	

**Notes:** TP301 --- Main CBA

Use Service remote control unit.

1. Enter the Service mode. (See Page 5-1) Then press number " 2 " button on the Service remote control unit.
2. Receive the Color Bar signal for channel 4 (67.25MHz). (RF Input Level: 60dBμV)
3. Press " CH ▲ / ▼ " buttons so that the voltage of TP301 becomes +2.5±0.1V DC. If the tuner is used TEDH9-309A. (Tuner type number)
4. Press " CH ▲ / ▼ " buttons so that the voltage of TP301 becomes +2.8±0.1V DC. If the tuner is used B8095AD. (Tuner type number)
5. Press " CH ▲ / ▼ " buttons so that the voltage of TP301 becomes +2.7±0.1V DC. If the tuner is used ENV56DB3G3. (Tuner type number)

6. Turn the Power off and on again. (Main power button on the TV unit.)

## 7. Black Level Adjustment

**Purpose:** Set Black Level

**Symptom of Misadjustment:** If black level is incorrect, Proper brightness can not be obtained by adjusting the Brightness Control.

1. Enter the Service mode. (See page 5-1).
2. Press " MENU " button on the Service remote control unit and select " BRT "mode. (Display changes " BRT ", " CNT ", " CLR " and " TNT "cyclically when MENU button is pressed).
3. Press " CH ▲ / ▼ " buttons on the Service remote control unit so that the value of " BRT " becomes 128.
4. Turn the power off and on again. (Main power button on the TV unit.)

## 8. C-Trap Adjustment

**Purpose:** To get minimum leakage of the color signal carrier.

**Symptom of Misadjustment:** If C- Trap Adjustment is incorrect, stripes will appears on the screen.

Test Point	Adj. Point	Mode	Input
TP1502(Blue) TP1501 (GND)	CH ▲ / ▼ buttons	RF	Color Bar
<b>Tape</b>	<b>M. EQ.</b>	<b>Spec.</b>	
---	Oscilloscope	---	

**Note:** TP1501, TP1502 --- CRT CBA

Use Service remote control unit.

1. Connect Oscilloscope to TP1502 and TP1501 (GND).
2. Enter the Service mode. (See Page 5-1) Receive color bar signal from RF Input.
3. Press " 0 " button on the Service remote control unit and select C-TRP Mode.
4. Press " CH ▲ / ▼ " buttons on the Service remote control unit so that the display will change " 0 ", " 1 ", " 2 " and " 3 ". Choose display " 0 ", " 1 ", " 2 " or " 3 " when B-Out (3.58MHz) value becomes minimum on the oscilloscope reading.
5. Turn the power off and on again. (Main power button on the TV unit.)



## 9. V. Size Adjustment

**Purpose:** To obtain correct vertical width of screen image.

**Symptom of Misadjustment:** If V. Size is incorrect, vertical size of image on the screen may not be properly displayed.

Test Point	Adj. Point	Mode	Input
---	Screen Control CH ▲ / ▼ buttons [ V-S ] Mode	RF	Monoscope
<b>Tape</b>	<b>M. EQ.</b>	<b>Spec.</b>	
---	Monoscope	90±5%	

**Note:** Use service remote control unit.

1. Operate the unit for at least 20 minutes.
2. Enter the Service mode. (See page 5-1)
3. Receive the Monoscope Pattern.
4. Press " 9 " button on the Service remote control unit and select " V-S " mode. (Display changes " V-S " and " V-P " cyclically when " 9 " button is pressed).
5. Press " CH ▲ / ▼ " buttons on the Service remote control unit so that the monoscope pattern will be 90±5% of display size and the circle is round.
6. Turn the power off and on again. (Main power button on the TV unit.)

## 10. V. Position Adjustment

**Purpose:** To obtain correct vertical width of screen image.

**Symptom of misadjustment:** If V. Position is incorrect, vertical height of image on the screen may not be properly displayed.

Test Point	Adj. Point	Mode	Input
---	Screen Control CH ▲ / ▼ buttons [ V-P ] Mode	RF	Monoscope
<b>Tape</b>	<b>M. EQ.</b>	<b>Spec.</b>	
---	Monoscope	90±5%	

**Note:** Use Service remote control unit

1. Operate the unit for at least 20 minutes.
2. Enter the Service Mode. (See page 5-1)
3. Receive the Monoscope Pattern.
4. Press " 9 " button on the Service remote control unit and select " V-P " mode. (Display change " V-S " and " V-P " cyclically when " 9 " button is pressed).
5. Press " CH ▲ / ▼ " buttons on the Service remote control unit so that the top and bottom of the monoscope pattern will be equal of each other.
6. Turn the Power off and on again. (Main power button on the TV unit.)

## 11. H. Position Adjustment

**Purpose:** To obtain correct horizontal position of screen image.

**Symptom of Misadjustment:** If H. Position is incorrect, horizontal position of image on the screen may not be properly displayed.

Test Point	Adj. Point	Mode	Input
---	Screen Control CH ▲ / ▼ buttons [ H-P ] Mode	RF	Monoscope
<b>Tape</b>	<b>M. EQ.</b>	<b>Spec.</b>	
---	Monoscope	90±5%	

**Note:** Use Service remote control unit

1. Operate the unit for at least 20 minutes.
2. Enter the Service mode. (See page 5-1)
3. Receive the Monoscope Pattern.
4. Press " 8 " button on the remote control unit and select " H-P " mode.
5. Press " CH ▲ / ▼ " buttons on the Service remote control unit so that the monoscope pattern will be 90±5% of display size and the circle is round.
6. Turn the Power off and on again. (Main power button on the TV unit.)

## 12. H. Size Adjustment

**Purpose:** To obtain correct horizontal size of screen image.

**Symptom of Misadjustment:** If H. Size is incorrect, horizontal size of image on the screen may not be properly displayed.

Test Point	Adj. Point	Mode	Input
---	VR562	RF	Monoscope
<b>Tape</b>	<b>M. EQ.</b>	<b>Spec.</b>	
---	Monoscope	90±5%	

**Note:** Use Service remote control unit

1. Operate the unit for at least 20 minutes.
2. Receive the Monoscope Pattern.
3. Adjust VR562 so that the monoscope pattern will be 90±5% of display size and circle is round.
4. Turn the Power off and on again. (Main power button on the TV unit.)

### 13. PIN Cushion Adjustment

**Purpose:** To obtain correct straight vertical line of screen image.

**Symptom of Misadjustment:** If H.Pin cushion is incorrect, vertical line of image on the screen may not be properly displayed.

Test Point	Adj. Point	Mode	Input
---	VR561	RF	Cross hatch
Tape	M. EQ.	Spec.	
---	Cross hatch		

**Note:** Use Service remote control unit

1. Operate the unit for at least 20 minutes.
2. Receive the Cross hatch Pattern.
3. Adjust VR561 so that the cross hatch pattern will be straight line of display.
4. Turn the Power off and on again. (Main power button on the TV unit.)

### 14. Cut-off Adjustment

**Purpose:** To adjust the beam current of R, G, B, and screen voltage.

**Symptom of Misadjustment:** White color may be reddish, greenish or bluish.

Test Point	Adj. Point	Mode	Input
---	Screen-Control CH ▲ / ▼ buttons	RF	Black Raster
Tape	M. EQ.	Spec.	
---	Pattern Generator	See Reference Notes below.	

**Figure**

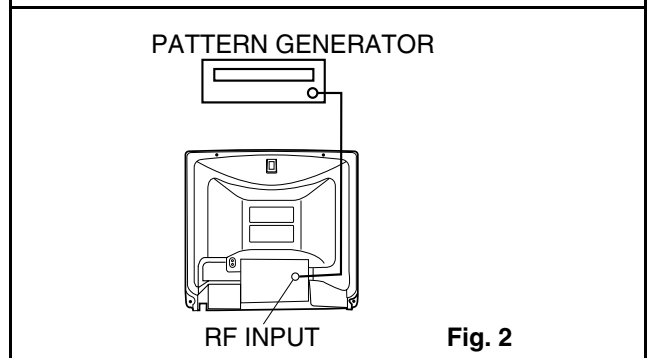

**Fig. 2**

**Note:** Screen Control FBT --- Main CBA  
F.B.T= Fly Back Transformer  
Use Service remote control unit

1. Degauss the CRT and allow CRT to operate for 20 minutes before starting the alignment.
2. Input the Black Raster Signal from RF Input.
3. Enter the Service mode. (See page 5-1)
4. Press " VOL ▼ " button on the Service remote control unit and select " C/D " mode. (Display changes " C/D ", " VCO ", " 7F ", " FRENCH ", " ACCESS CODE ", " STEREO ", " VIDEO TONE ", " FM-MODE ", and " AV-OUT " cyclically when " VOL ▼ " button is pressed.) then press " 1 ". The display will momentarily show " CUT OFF R " (R= Red). Now there should be a horizontal line across the center of the picture tube. If needed gradually turn the screen control on the flyback, clockwise until the horizontal line appears. Adjust the Red Cut off by pressing the " CH ▲ / ▼ " buttons. Proceed to Step 5 when the Red Cut off adjustment is done.
5. Press the " 2 " button. The display will momentarily show " CUT OFF G " (G=Green). Adjust the Green Cut off by pressing the " CH ▲ / ▼ " buttons. Proceed to step 6 when the Green Cut off adjustment is done.
6. Press the " 3 " button. The display will momentarily show " CUT OFF B " (B=Blue). Adjust the Blue cut off by pressing the " CH ▲ / ▼ " buttons. When done with steps 4, 5 and 6 the horizontal line should be pure white if not, then attempt the Cut off adjustment again.

## 15. White Balance Adjustment

**Purpose:** To mix red, green and blue beams correctly for pure white.

**Symptom of Misadjustment:** White becomes bluish or reddish.

Test Point	Adj. Point	Mode	Input
Screen	CH ▲ / ▼ buttons	RF	White Raster (APL 100%)
<b>Tape</b>	<b>M. EQ.</b>	<b>Spec.</b>	
	Pattern Generator, Color analyzer	See below	

**Figure**

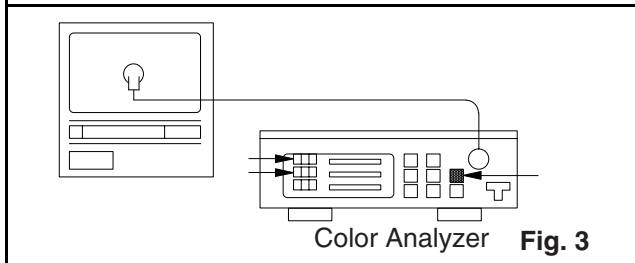

**Note:** Use Service remote control unit

- Operate the unit more than 20 minutes.
- Face the unit to east. Degauss the CRT using Degaussing Coil.
- Input the White Raster (APL 100%).
- Set the color analyzer to the CHROMA mode and after zero point calibration, bring the optical receptor to the center on the tube surface (CRT).
- Enter the Service mode. Press "VOL ▼" button on the Service remote control unit and select "C/D" mode. (Display changes "C/D", "VCO", "7F", "FRENCH", "ACCESS CODE", "STEREO", "VIDEO TONE", "FM-MODE", and "AV-OUT" cyclically when "VOL ▼" button is pressed.) then Press No. 8 button on the Service remote control Unit.
- Press No. 4 button on the service remote control unit for Red adjustment. Press NO. 5 button on the Service remote control unit for Blue adjustment.
- In each color mode, Press "CH ▲ / ▼" button to adjust the values of color.
- Adjusting Red and Blue color so that the temperature becomes 9200K (x : 286 / y : 294)±3%.
- At this time, Re-check that Horizontal line is white. If not, Re-adjust Cut-off Adjustment until the Horizontal Line becomes pure white.
- Turn off and on again to return to normal mode. Receive APL 100% white signal and Check Chroma temperatures become 9200K (x : 286 / y : 294)±3%.

**Note:** Confirm that Cut Off Adj. is correct after this adjustment, and attempt Cut Off Adj. if needed.

## 16. Sub-Brightness Adjustment

**Purpose:** To get proper brightness.

**Symptom of Misadjustment:** If Sub-Brightness is incorrect, proper brightness cannot be obtained by adjusting the Brightness Control.

Test Point	Adj. Point	Mode	Input
---	CH ▲ / ▼ buttons	RF	IQW
<b>Tape</b>	<b>M. EQ.</b>	<b>Spec.</b>	
---	Pattern Generator	See below	

**Figure**

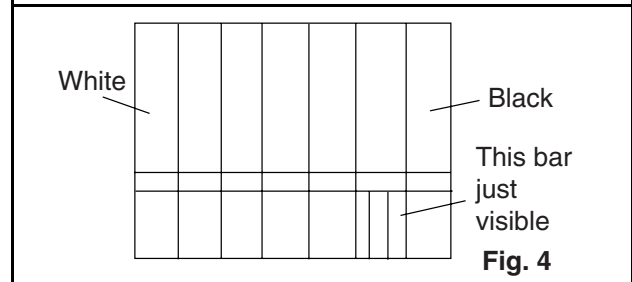

**Note:** IQW Setup level --- 7.5 IRE

Use Service remote control unit

- Enter the Service mode. (See page 5-1) Then input IQW signal from RF Input.
- Press "MENU" button on the Service remote control unit and Select "BRT" mode. (Display changes "BRT", "CNT", "CLR", and "TNT" cyclically when MENU button is pressed). Press "CH ▲ / ▼" buttons so that the bar is just visible (See above figure).
- Turn the power off and on again. (Main power button on the TV unit.)

## 17. Focus Adjustment

**Purpose:** Set the optimum Focus.

**Symptom of Misadjustment:** If Focus Adjustment is incorrect, blurred images are shown on the display.

Test Point	Adj. Point	Mode	Input
---	Focus Control	---	Monoscope
Tape	M. EQ.	Spec.	
---	Pattern Generator	See below	

**Note:** Focus VR (FBT) - Main CBA FBT=Fly Back Transformer

1. Operate the unit more than 30 minutes
2. Face the unit to the East and Degauss the CRT using Degaussing Coil.
3. Input the Monoscope Pattern.
4. Adjust the Focus Control on the FBT to obtain clear picture.

The following 2 adjustments normally are not attempted in the field. Only when replacing the CRT then adjust as a preparation.

## 18. Purity Adjustment

**Purpose:** To obtain pure color.

**Symptom of Misadjustment:** If Color Purity Adjustment is incorrect, large areas of color may not be properly displayed.

Test Point	Adj. Point	Mode	Input
---	Deflection Yoke Purity Magnet	---	Red Color
Tape	M. EQ.	Spec.	
---	Pattern Generator	See below.	

**Figure**

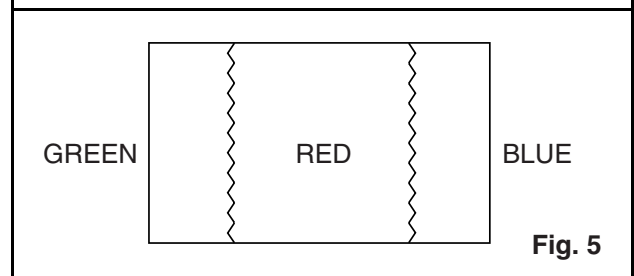

1. Set the unit facing east.
2. Operate the unit for over 30 minutes before adjusting.
3. Fully degauss the unit using an external degaussing coil.
4. Loosen the screw on the Deflection Yoke Clamper and pull the Deflection Yoke back away from the screen. (See Fig. 6)
5. Loosen the Ring Lock and adjust the Purity Magnets so that a red field is obtained at the center of the screen. Tighten Ring Lock. (See Fig. 5,6)
6. Slowly push the Deflection Yoke toward bell of CRT and set it where a uniform red field is obtained.
7. Tighten the clamp screw on the Deflection Yoke.

# 19. Convergence Adjustment

**Purpose:** To obtain proper convergence of red, green and blue beams.

**Symptom of Misadjustment:** If Convergence Adjustment is incorrect, the edge of white letters may have color edges.

Test Point	Adj. Point	Mode	Input
---	C.P. Magnet (RB), C.P. Magnet (RB-G), Deflection Yoke	---	Dot Pattern or Crosshatch
Tape	M. EQ.	Spec.	
---	Pattern Generator	See below.	

### Figures

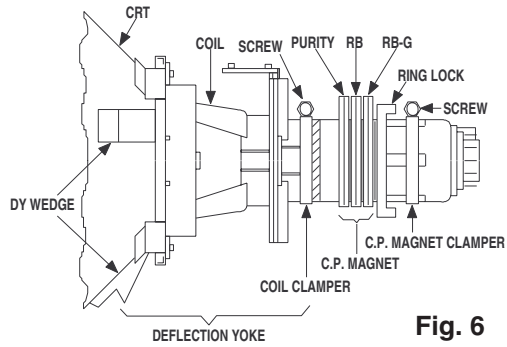

Fig. 6

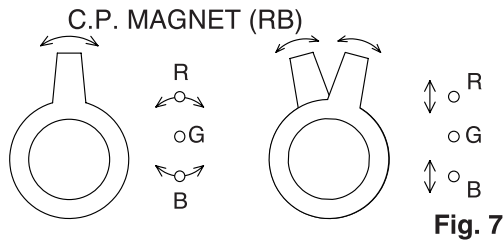

Fig. 7

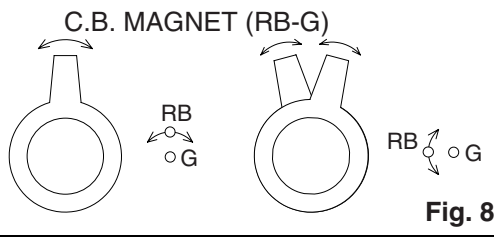
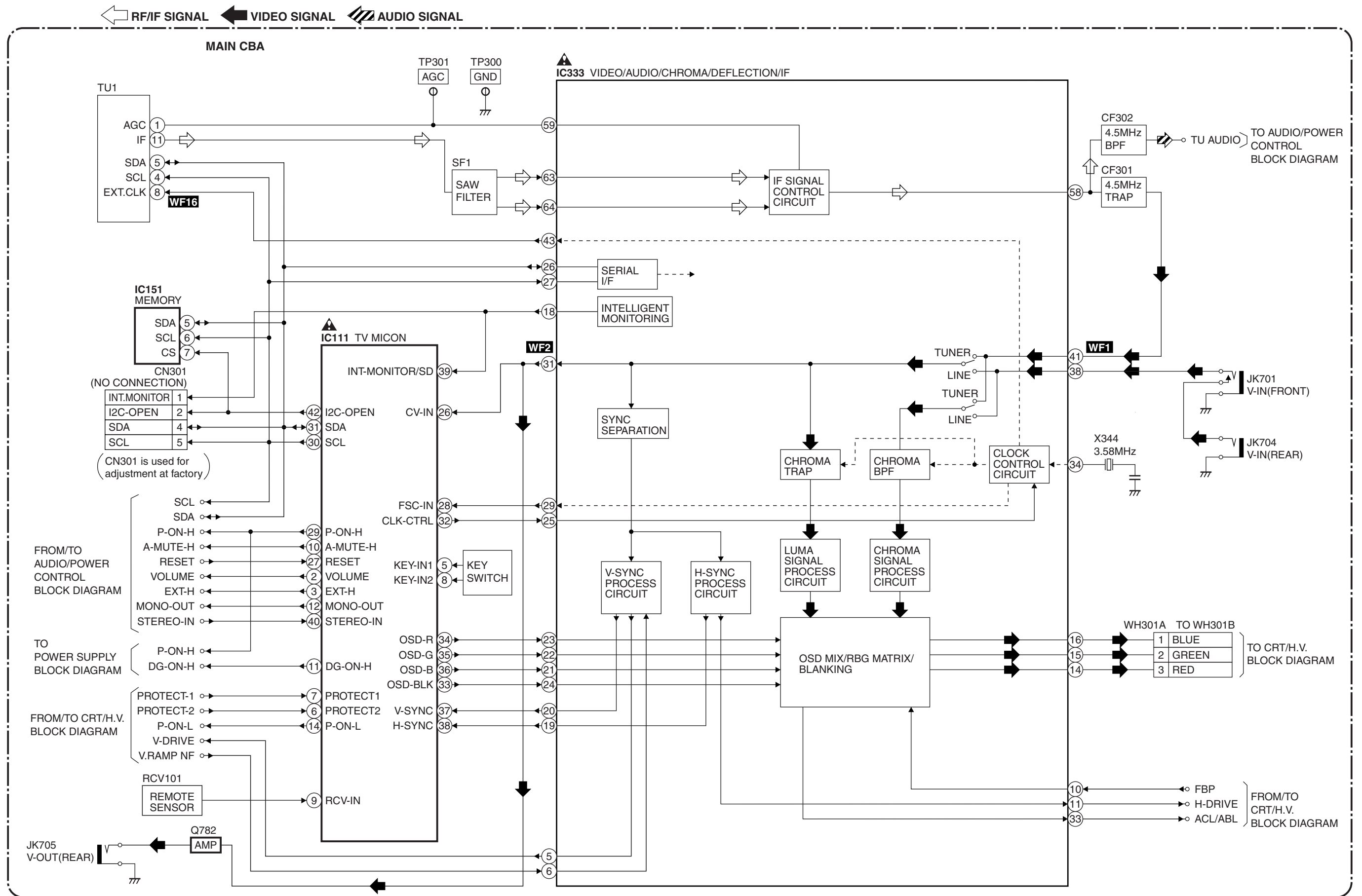

Fig. 8

1. Loosen the Ring Lock and align red with blue dots or Crosshatch at the center of the screen by rotating (RB) C.P. Magnets. (See Fig. 7)
2. Align red / blue with green dots at the center of the screen by rotating (RB-G) C.P. Magnet. (See Fig. 8)
3. Fix the C.P. Magnets by tightening the Ring Lock.
4. Remove the DY Wedges and slightly tilt the Deflection Yoke horizontally and vertically to obtain the best overall convergence.
5. Fix the Deflection Yoke by carefully inserting the DY Wedges between CRT and Deflection Yoke.

# BLOCK DIAGRAMS

## IF/Video/System Control Block Diagram



# Audio/Power Control Block Diagram

AUDIO SIGNAL

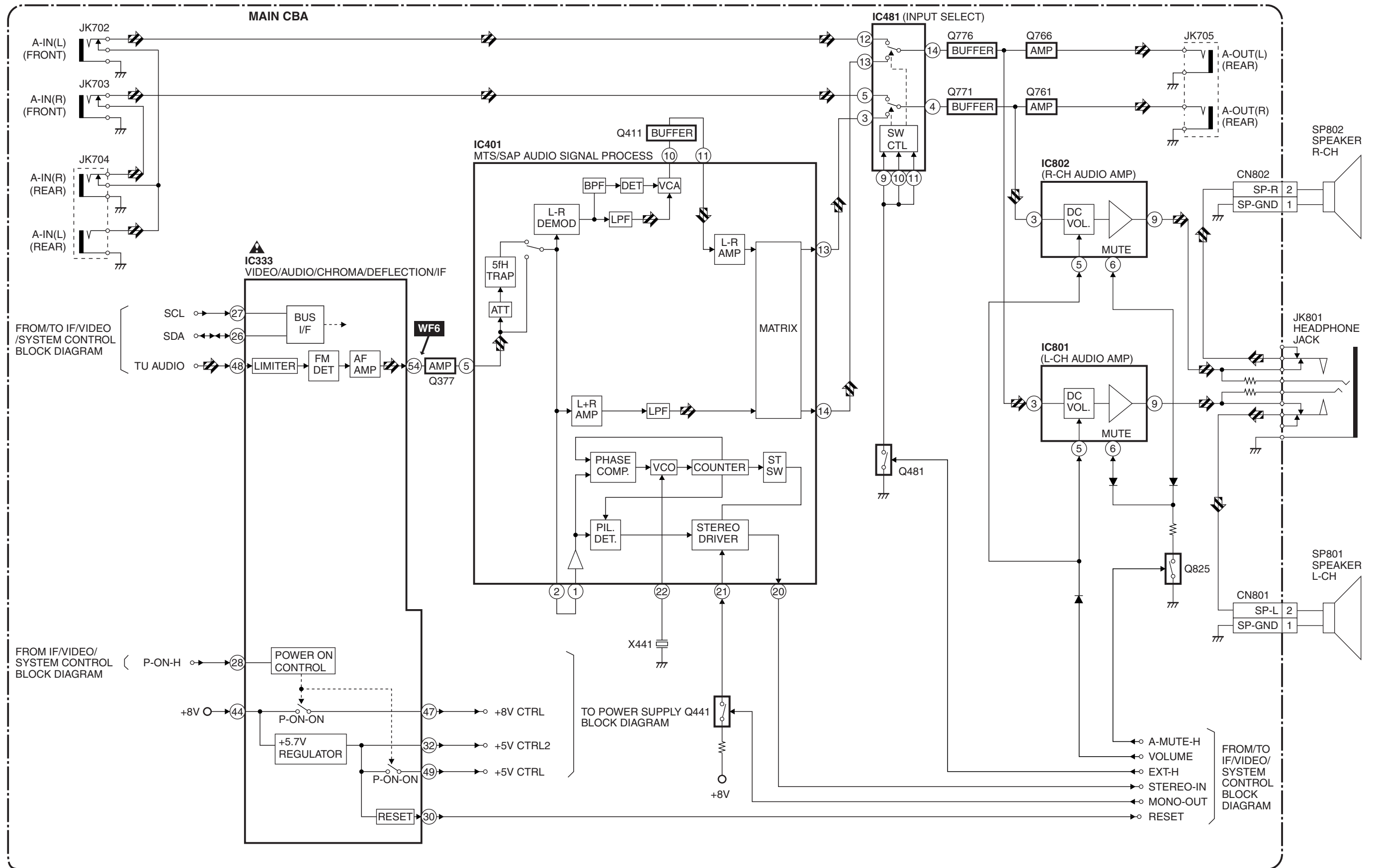

# CRT/H.V. Block Diagram

← VIDEO SIGNAL

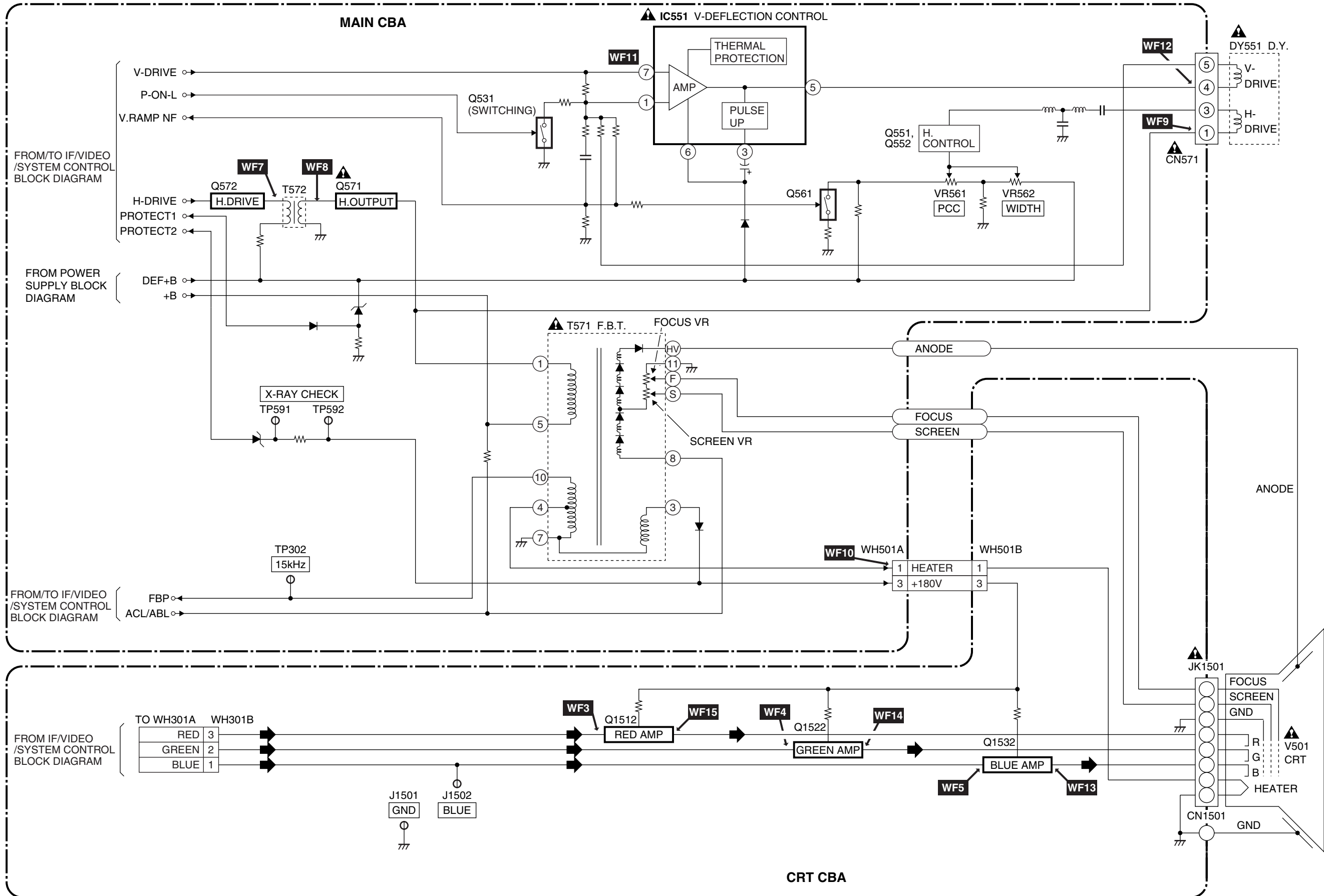



# Power Supply Block Diagram

**CAUTION !**

Switching power supply circuit is used in this unit.  
If Main Fuse (F601) is blown, check to see that all components in the power supply circuit are not defective before you connect the AC plug to the AC power supply.  
Otherwise it may cause some components in the power supply circuit to fail.

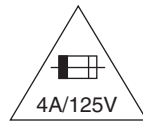

**CAUTION**

FOR CONTINUED PROTECTION AGAINST FIRE HAZARD,  
REPLACE ONLY WITH THE SAME TYPE FUSE.  
ATTENTION : POUR UNE PROTECTION CONTINUE LES RISQUES  
D'INCELE N'UTILISER QUE DES FUSIBLE DE MEMO TYPE.  
**RISK OF FIRE-REPLACE FUSE AS MARKED.**

"This symbol means fast operating fuse."  
"Ce symbole représente un fusible à fusion rapide."

**NOTE :**

The voltage for parts in hot circuit is measured using hot GND as a common terminal.

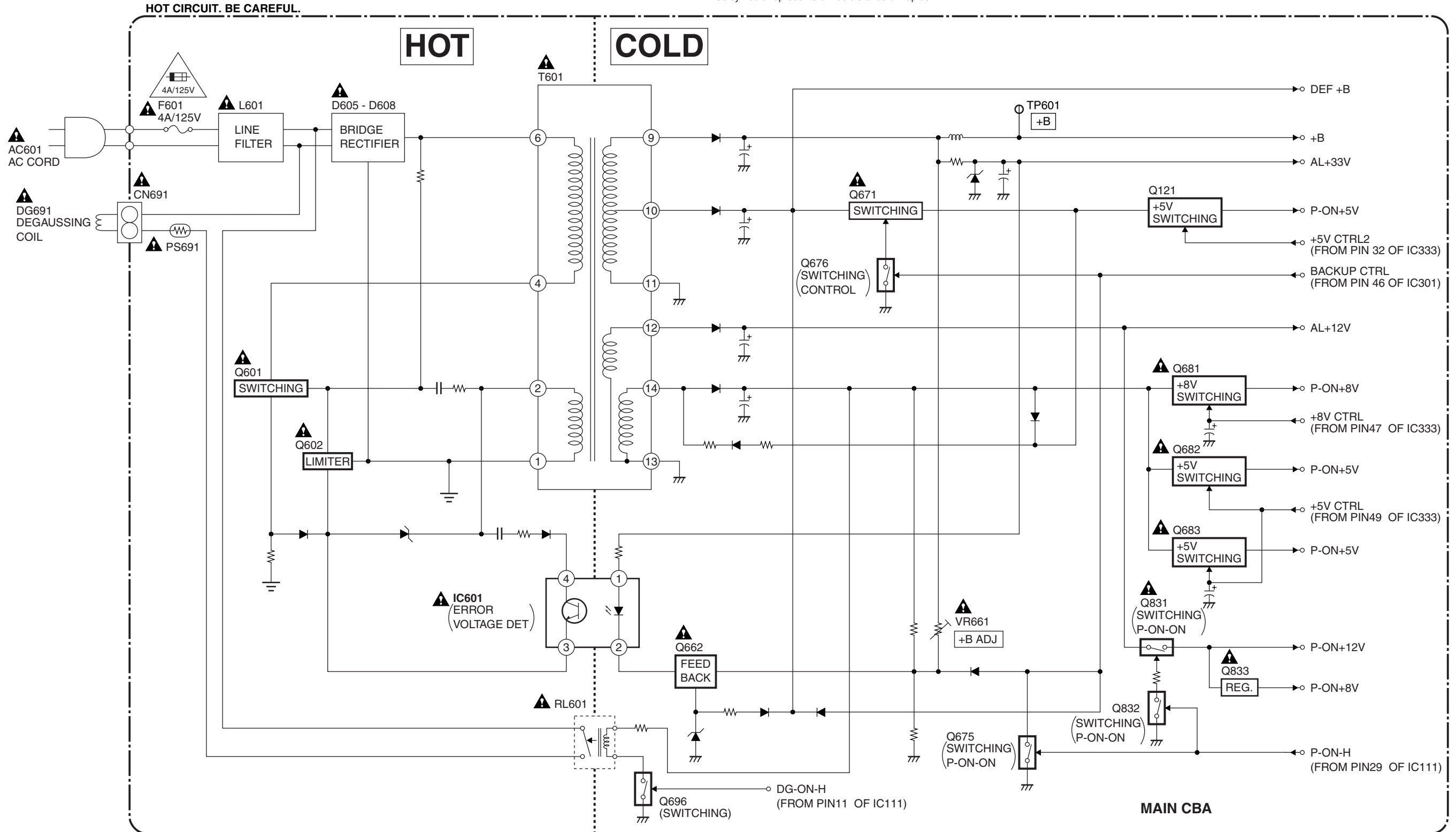

HOT CIRCUIT. BE CAREFUL.

# SCHEMATIC DIAGRAMS / CBA'S AND TEST POINTS

## Standard Notes

Many electrical and mechanical parts in this chassis have special characteristics. These characteristics often pass unnoticed and the protection afforded by them cannot necessarily be obtained by using replacement components rated for higher voltage, wattage, etc. Replacement parts that have these special safety characteristics are identified in this manual and its supplements; electrical components having such features are identified by the mark "▲" in the schematic diagram and the parts list. Before replacing any of these components, read the parts list in this manual carefully. The use of substitute replacement parts that do not have the same safety characteristics as specified in the parts list may create shock, fire, or other hazards.

### Note:

1. Do not use the part number shown on these drawings for ordering. The correct part number is shown in the parts list, and may be slightly different or amended since these drawings were prepared.
2. All resistance values are indicated in ohms ( $K=10^3$ ,  $M=10^6$ ).
3. Resistor wattages are 1/4W or 1/6W unless otherwise specified.
4. All capacitance values are indicated in  $\mu F$  ( $P=10^{-6}\mu F$ ).
5. All voltages are DC voltages unless otherwise specified.

### Note of Capacitors:

ML --- Mylar Cap. PP --- Metalized Film Cap. SC --- Semiconductor Cap. L --- Low Leakage type

### Temperature Characteristics of Capacitors are noted with the following:

B ---  $\pm 10\%$  CH ---  $0\pm 60\text{ppm}/^\circ\text{C}$  CSL ---  $+350\sim -1000\text{ppm}/^\circ\text{C}$

### Tolerance of Capacitors are noted with the following:

Z ---  $+80\sim -20\%$

### Note of Resistors:

CEM --- Cement Res. MTL --- Metal Res. F --- Fuse Res.

Capacitors and transistors are represented by the following symbols.

#### CBA Symbols

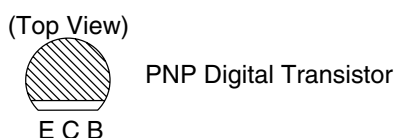
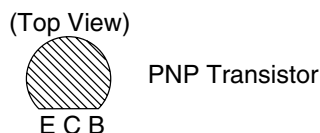
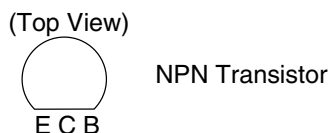
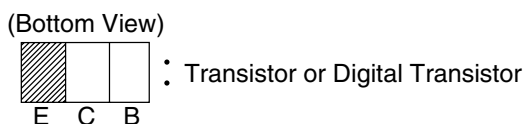
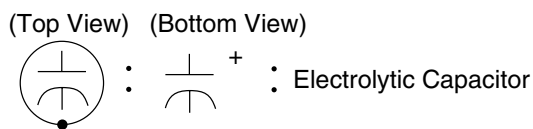

#### Schematic Diagram Symbols

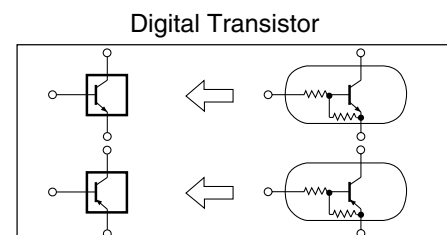

## LIST OF CAUTION, NOTES, AND SYMBOLS USED IN THE SCHEMATIC DIAGRAMS ON THE FOLLOWING PAGES:

1. **CAUTION:** FOR CONTINUED PROTECTION AGAINST FIRE HAZARD, REPLACE ONLY WITH THE SAME TYPE FUSE. ATTENTION: POUR UNE PROTECTION CONTINUE LES RISQUES D'INCELE N'UTILISER QUE DES FUSIBLE DE MEMO TYPE.

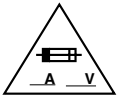

RISK OF FIRE-REPLACE FUSE AS MARKED.

2. **CAUTION:**

Fixed Voltage (or Auto voltage selectable) power supply circuit is used in this unit.

If Main Fuse (F601) is blown, first check to see that all components in the power supply circuit are not defective before you connect the AC plug to the AC power supply. Otherwise it may cause some components in the power supply circuit to fail.

3. **Note:**

- (1) Do not use the part number shown on the drawings for ordering. The correct part number is shown in the parts list, and may be slightly different or amended since the drawings were prepared.
- (2) To maintain original function and reliability of repaired units, use only original replacement parts which are listed with their part numbers in the parts list section of the service manual.

4. Wire Connectors

- (1) Prefix symbol "CN" means "connector" (can disconnect and reconnect).
- (2) Prefix symbol "CL" means "wire-solder holes of the PCB" (wire is soldered directly).

5. Note: Mark "●" is a leadless (chip) component.

6. Voltage indications on the schematics are as shown below:  
Plug the TV power cord into a standard AC outlet.:

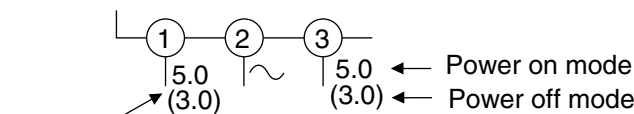

Indicates that the voltage is not consistent here.

Unit: Volts

7. How to read converged lines

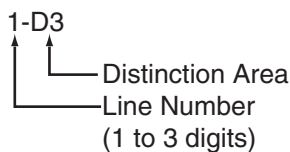

Examples:

1. "1-D3" means that line number "1" goes to area "D3".
2. "1-B1" means that line number "1" goes to area "B1".

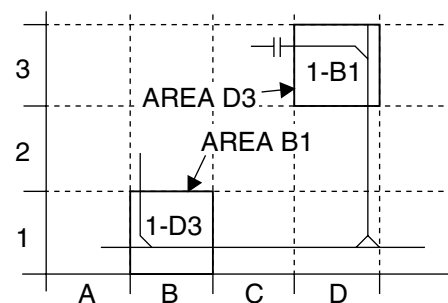

8. Test Point Information

⊙ : Indicates a test point with a jumper wire across a hole in the PCB.

□→ : Used to indicate a test point with a component lead on foil side.

⊘ : Used to indicate a test point with no test pin.

● : Used to indicate a test point with a test pin.

Main 1/3 Schematic Diagram

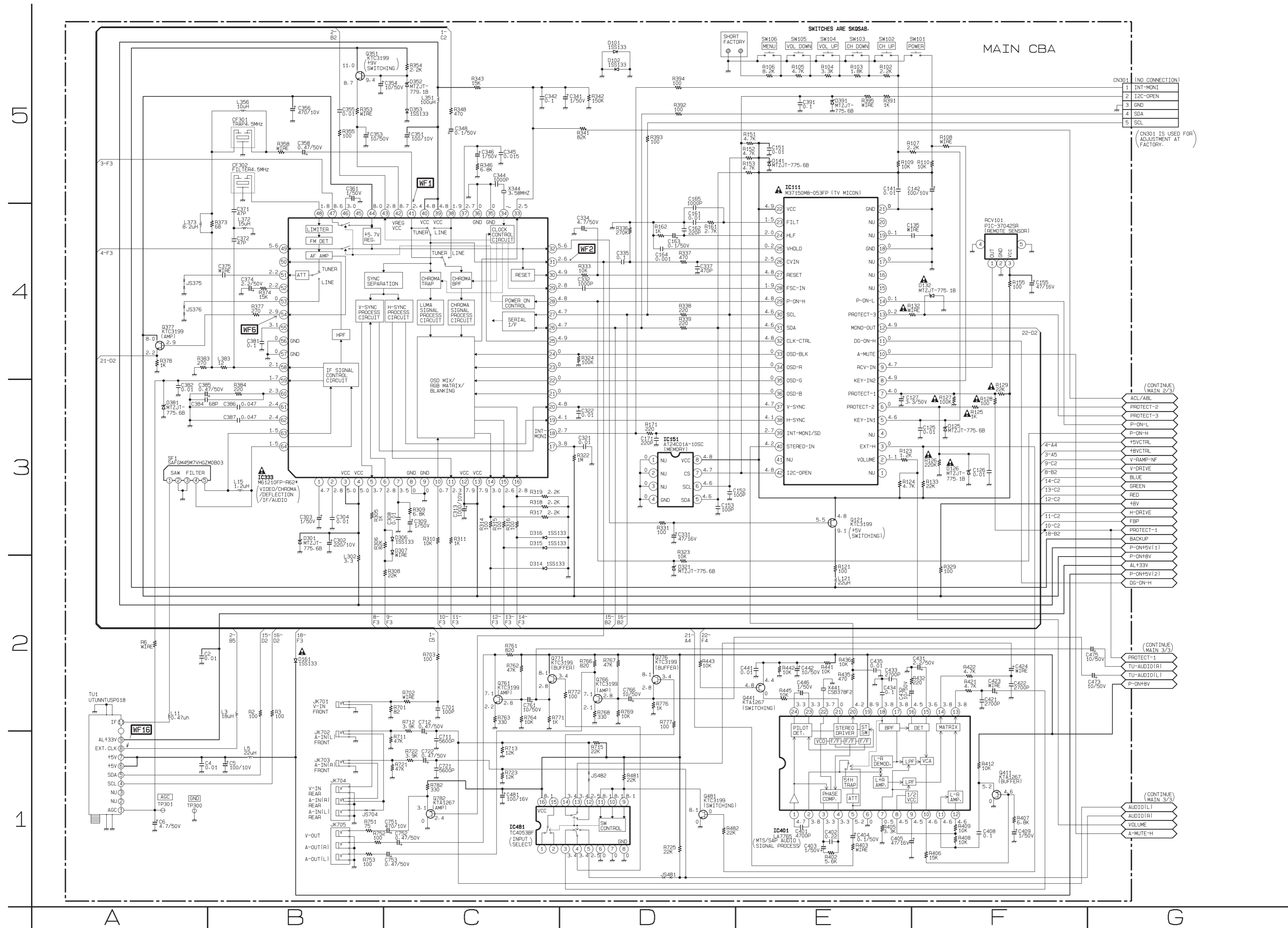

MAIN 1/3

Ref No.	Position
ICS	
IC111	E-5
IC151	D-3
IC333	B-3
IC401	E-1
IC481	C-1
TRANSISTORS	
Q121	E-3
Q351	B-5
Q377	A-4
Q411	F-1
Q441	E-2
Q481	D-1
Q761	C-2
Q766	D-2
Q771	C-2
Q782	C-1
TEST POINTS	
TP300	A-1
TP301	A-1
CONNECTOR	
CN301	G-5

7  
 4  
 3  
 2  
 1

A      B      C      D      E      F      G

A5	B5	C5	D5	E5	F5	G5
A4	B4	C4	D4	E4	F4	G4
A3	B3	C3	D3	E3	F3	G3
A2	B2	C2	D2	E2	F2	G2
A1	B1	C1	D1	E1	F1	G1

--- IF SIGNAL  
— VIDEO SIGNAL  
◀ AUDIO SIGNAL

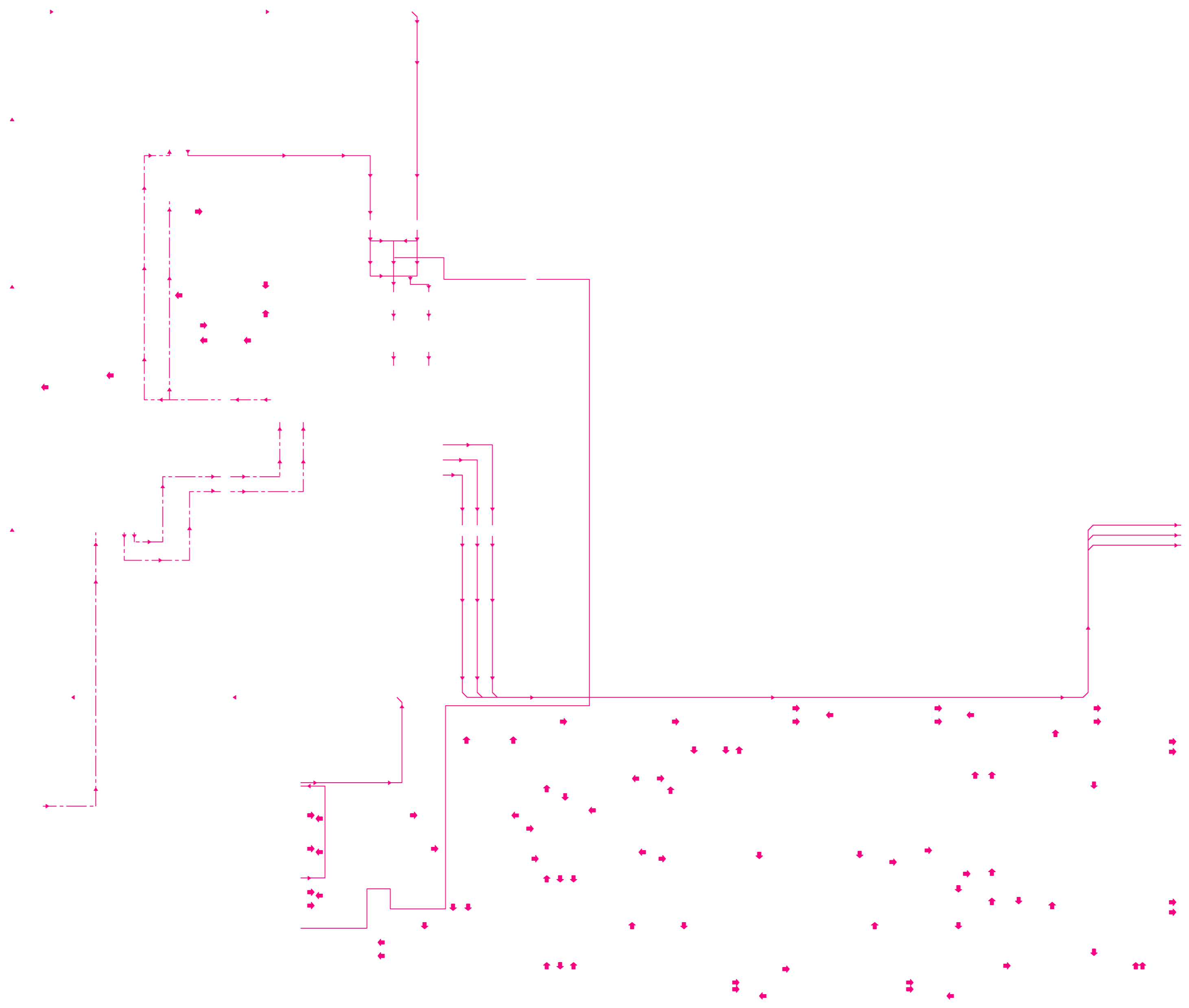

# Main 2/3 & CRT Schematic Diagram

## CAUTION !

Fixed voltage power supply circuit is used in this unit.  
If Main Fuse (F601) is blown, check to see that all components in the power supply circuit are not defective before you connect the AC plug to the AC power supply.  
Otherwise it may cause some components in the power supply circuit to fail.

## NOTE :

The voltage for parts in hot circuit is measured using hot GND as a common terminal.

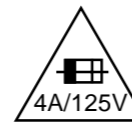

## CAUTION

FOR CONTINUED PROTECTION AGAINST FIRE HAZARD, REPLACE ONLY WITH THE SAME TYPE FUSE.  
ATTENTION : POUR UNE PROTECTION CONTINUE LES RISQUES D'INCEPTE UTILISER QUE DES FUSIBLE DE MEMO TYPE.  
RISK OF FIRE-REPLACE FUSE AS MARKED.

"This symbol means fast operating fuse."  
"Ce symbole représente un fusible à fusion rapide."

BECAUSE A HOT CHASSIS GROUND IS PRESENT IN THE POWER SUPPLY CIRCUIT, AN ISOLATION TRANSFORMER MUST BE USED.  
ALSO, IN ORDER TO HAVE THE ABILITY TO INCREASE THE INPUT SLOWLY, WHEN TROUBLESHOOTING THIS TYPE POWER SUPPLY CIRCUIT, A VARIABLE ISOLATION TRANSFORMER IS REQUIRED.

## \*1 NOTE:

The Capacitor ( C643 ) is either type A or type B.  
These two types are exchangeable and can be equally used whichever the model is . The difference between type A and type B is shown in the table below.

	C643	C642	JS642
Type A	0.01/250V	0.01/250V	Not Used
Type B	4700P/250V	Not Used	WIRE

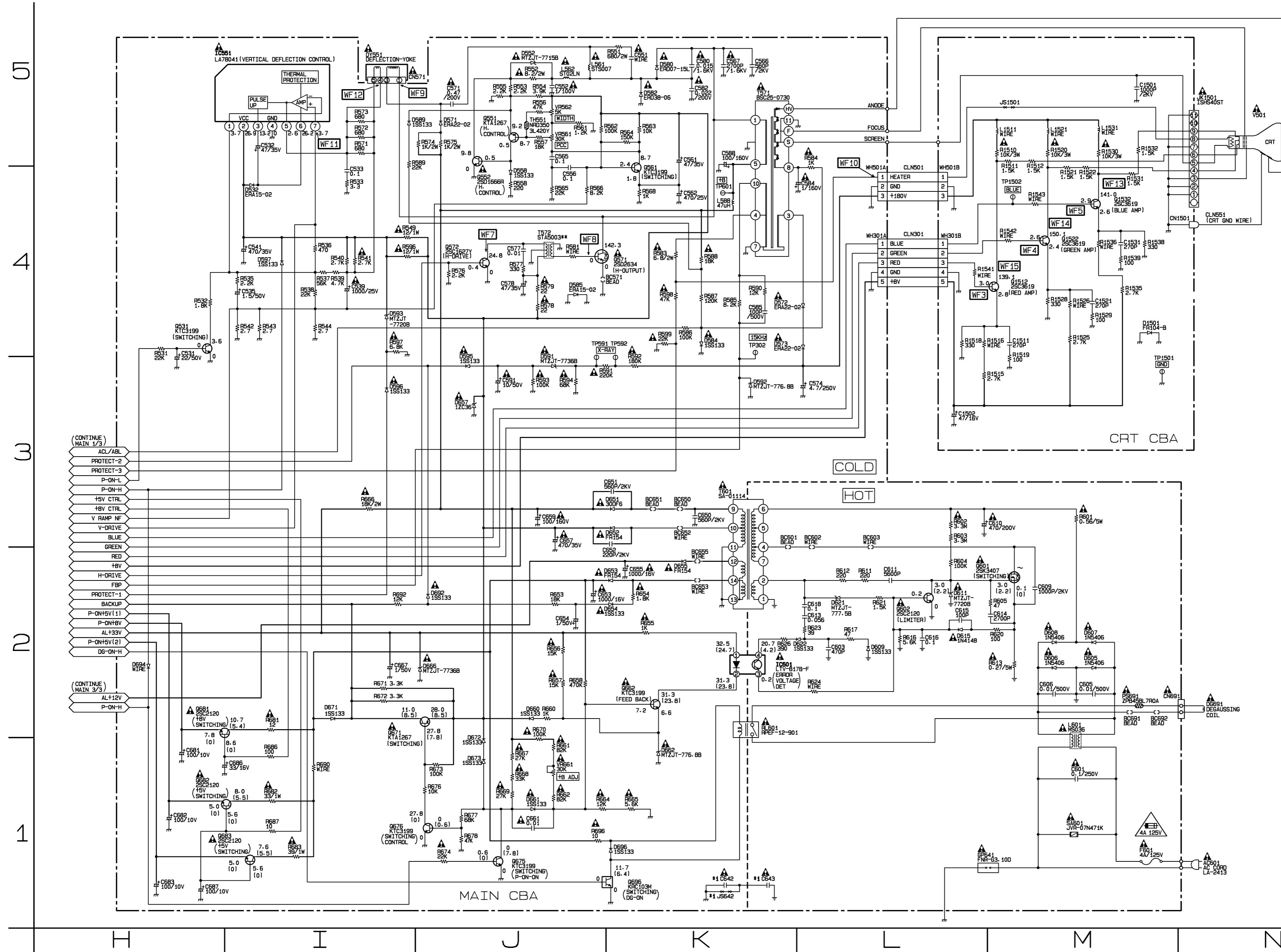

CRT

Ref No.	Position
TRANSISTORS	
Q1512	M-4
Q1522	M-4
Q1532	M-4
TEST POINTS	
TP1501	M-4
TP1502	M-4
CONNECTORS	
CN1501	M-4
WH301A	L-4
WH501B	L-5

MAIN 2/3

Ref No.	Position
ICS	
IC501	H-5
IC601	K-2
TRANSISTORS	
Q531	H-4
Q551	J-5
Q552	J-4
Q561	K-4
Q571	K-4
Q572	J-4
Q601	L-2
Q602	L-2
Q662	K-2
Q671	I-2
Q675	J-1
Q676	I-1
Q681	H-2
Q682	H-1
Q683	H-1
Q696	K-1
TEST POINTS	
TP302	K-4
TP591	J-4
TP592	K-4
TP601	K-4
CONNECTORS	
CN571	I-5
CN691	M-2
WH301A	L-4
WH501A	L-4
VARIABLE RESISTORS	
VR561	J-5
VR562	J-5
VR661	J-1

H5	I5	J5	K5	L5	M5	N5
H4	I4	J4	K4	L4	M4	N4
H3	I3	J3	K3	L3	M3	N3
H2	I2	J2	K2	L2	M2	N2
H1	I1	J1	K1	L1	M1	N1



VIDEO SIGNAL

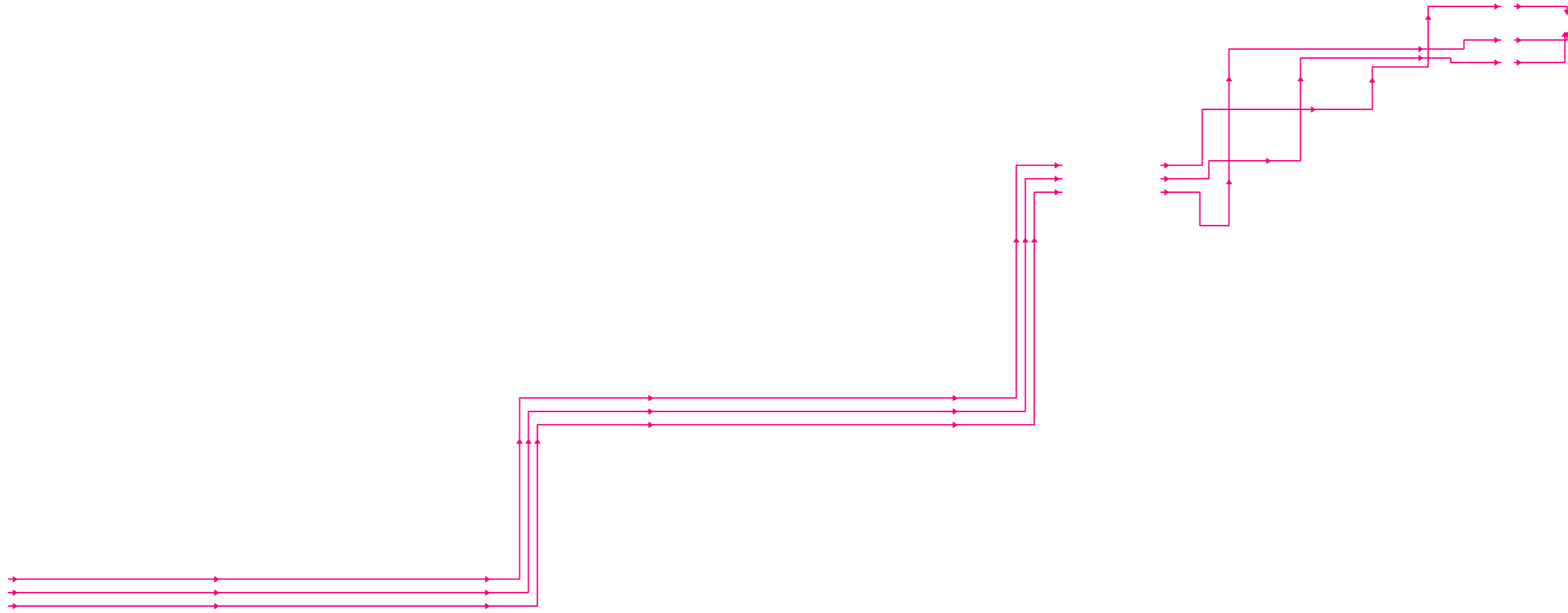

# Main 3/3 Schematic Diagram

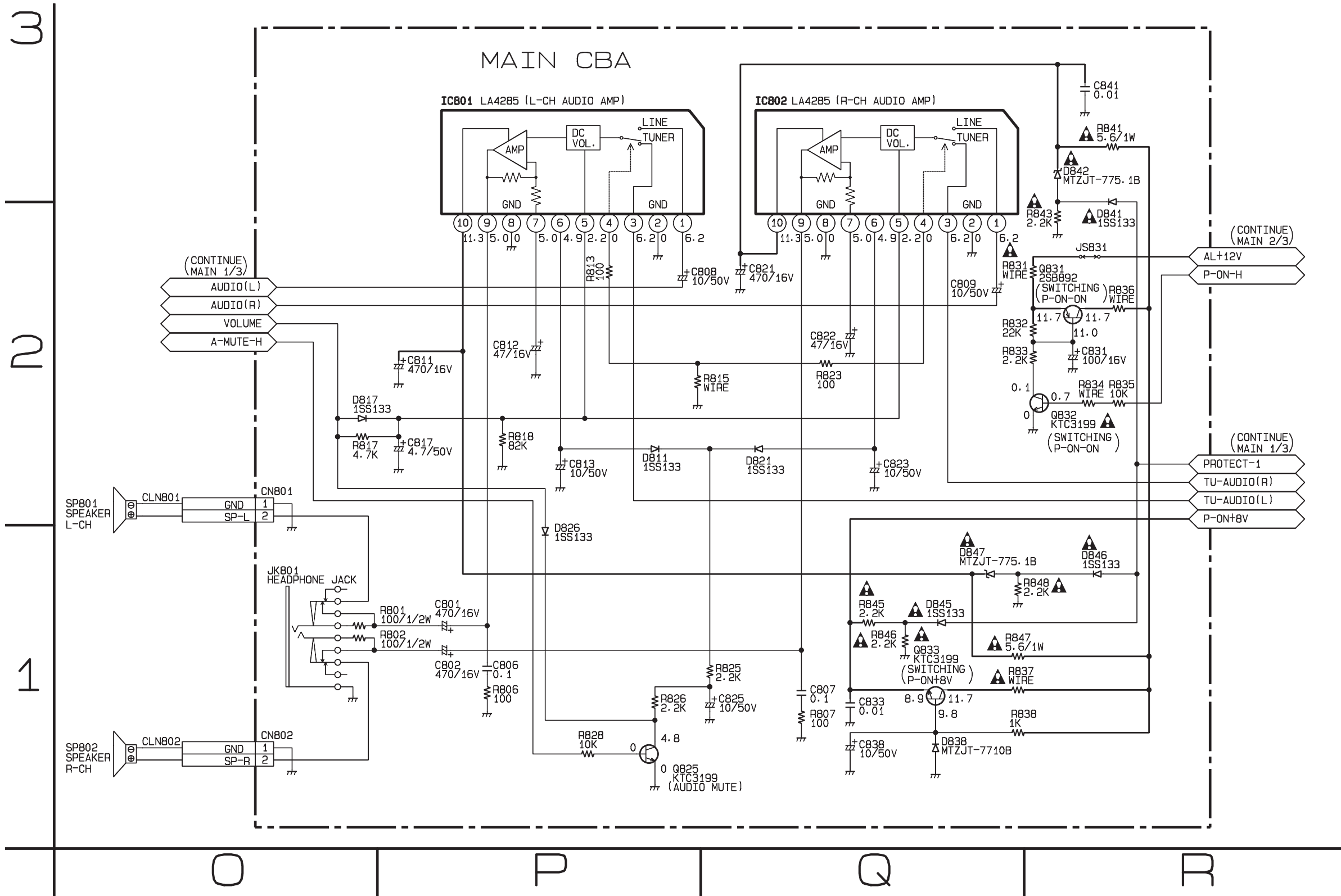

MAIN 3/3

Ref No.	Position
ICS	
IC801	P-3
IC802	Q-3
TRANSISTORS	
Q825	P-1
Q831	R-2
Q832	R-2
Q833	Q-1
CONNECTOR	
CN801	O-2
CN802	O-1

O3	P3	Q3	R3
O2	P2	Q2	R2
O1	P1	Q1	R1



CRT CBA Top View

CRT CBA Bottom View

CRT CBA

Ref No.	Position
TRANSISTORS	
Q1512	C-2
Q1522	C-1
Q1532	A-2
TEST POINTS	
TP1501	A-2
TP1502	A-2
CONNECTORS	
CN1501	A-2
WH301B	C-1
WH501B	B-1

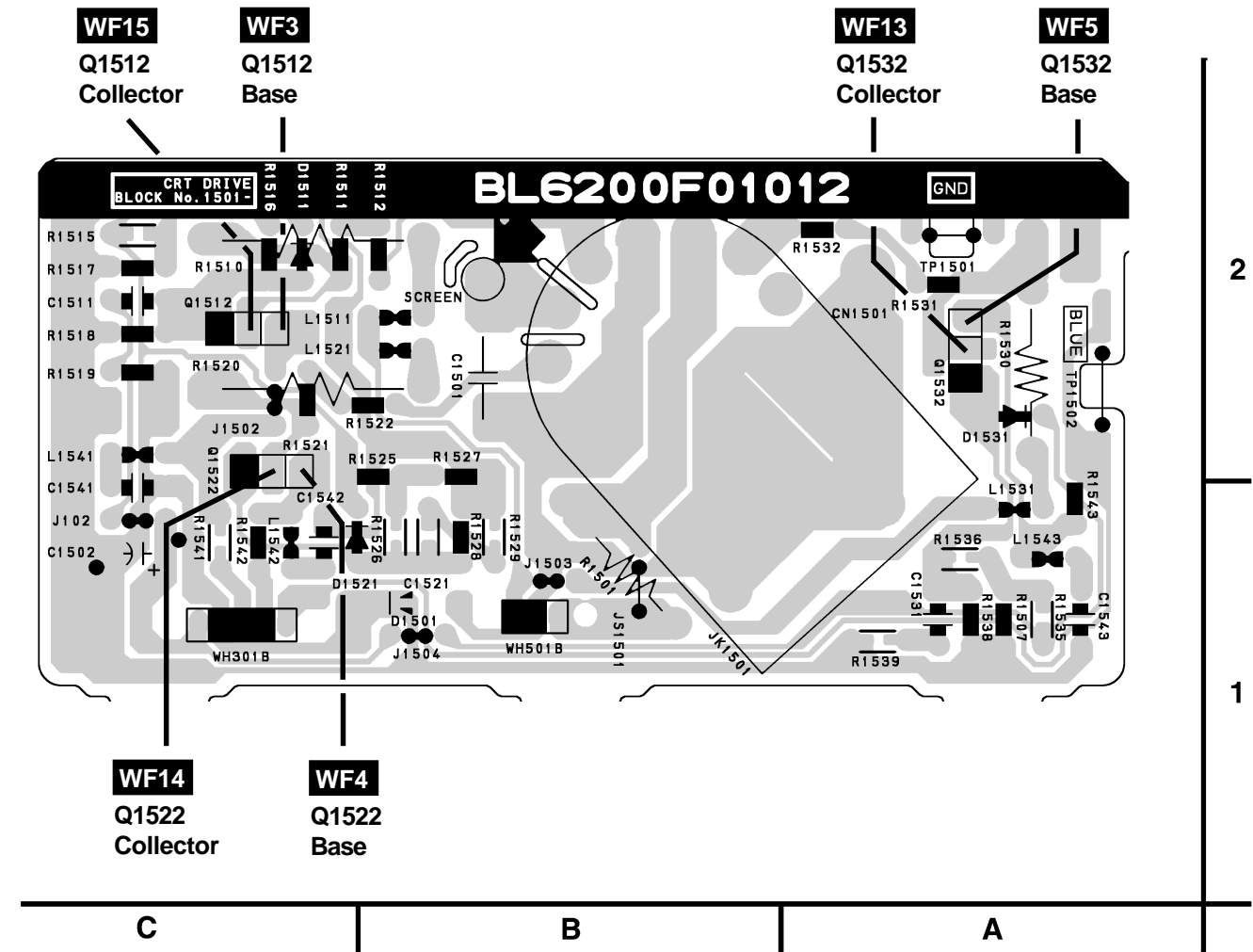
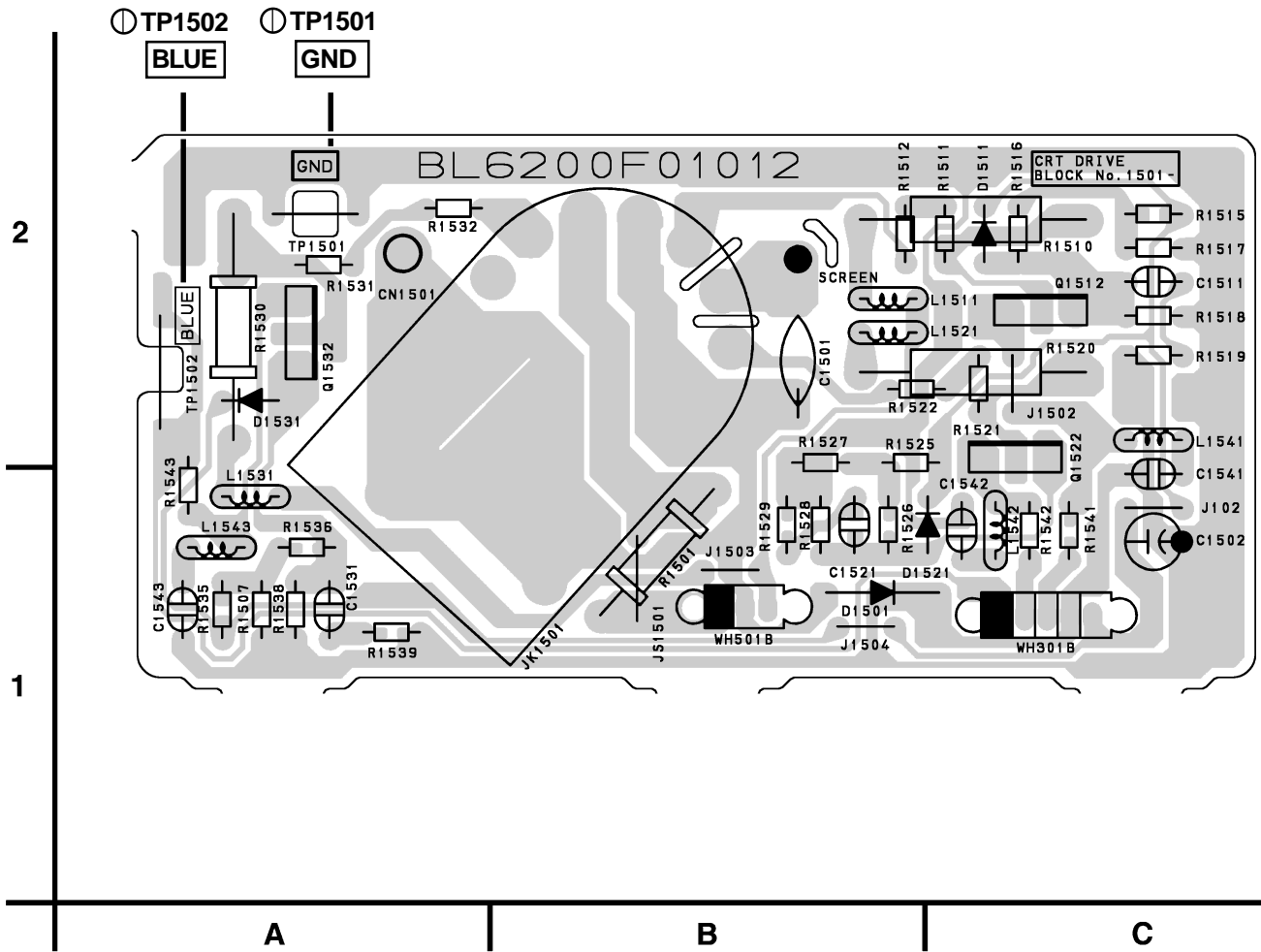

Main CBA Top View

**CAUTION !**  
Fixed voltage power supply circuit is used in this unit.  
If Main Fuse (F601) is blown, check to see that all components in the power supply circuit are not defective before you connect the AC plug to the AC power supply.  
Otherwise it may cause some components in the power supply circuit to fail.



**CAUTION**  
FOR CONTINUED PROTECTION AGAINST FIRE HAZARD,  
REPLACE ONLY WITH THE SAME TYPE FUSE.  
ATTENTION : POUR UNE PROTECTION CONTINUE LES RISQUES  
D'INCELE N'UTILISER QUE DES FUSIBLE DE MEMO TYPE.  
**RISK OF FIRE-REPLACE FUSE AS MARKED.**

\*This symbol means fast operating fuse.\*  
\*Ce symbole représente un fusible à fusion rapide.\*

**BECAUSE A HOT CHASSIS GROUND IS PRESENT IN THE POWER SUPPLY CIRCUIT, AN ISOLATION TRANSFORMER MUST BE USED. ALSO, IN ORDER TO HAVE THE ABILITY TO INCREASE THE INPUT SLOWLY, WHEN TROUBLESHOOTING THIS TYPE POWER SUPPLY CIRCUIT, A VARIABLE ISOLATION TRANSFORMER IS REQUIRED.**

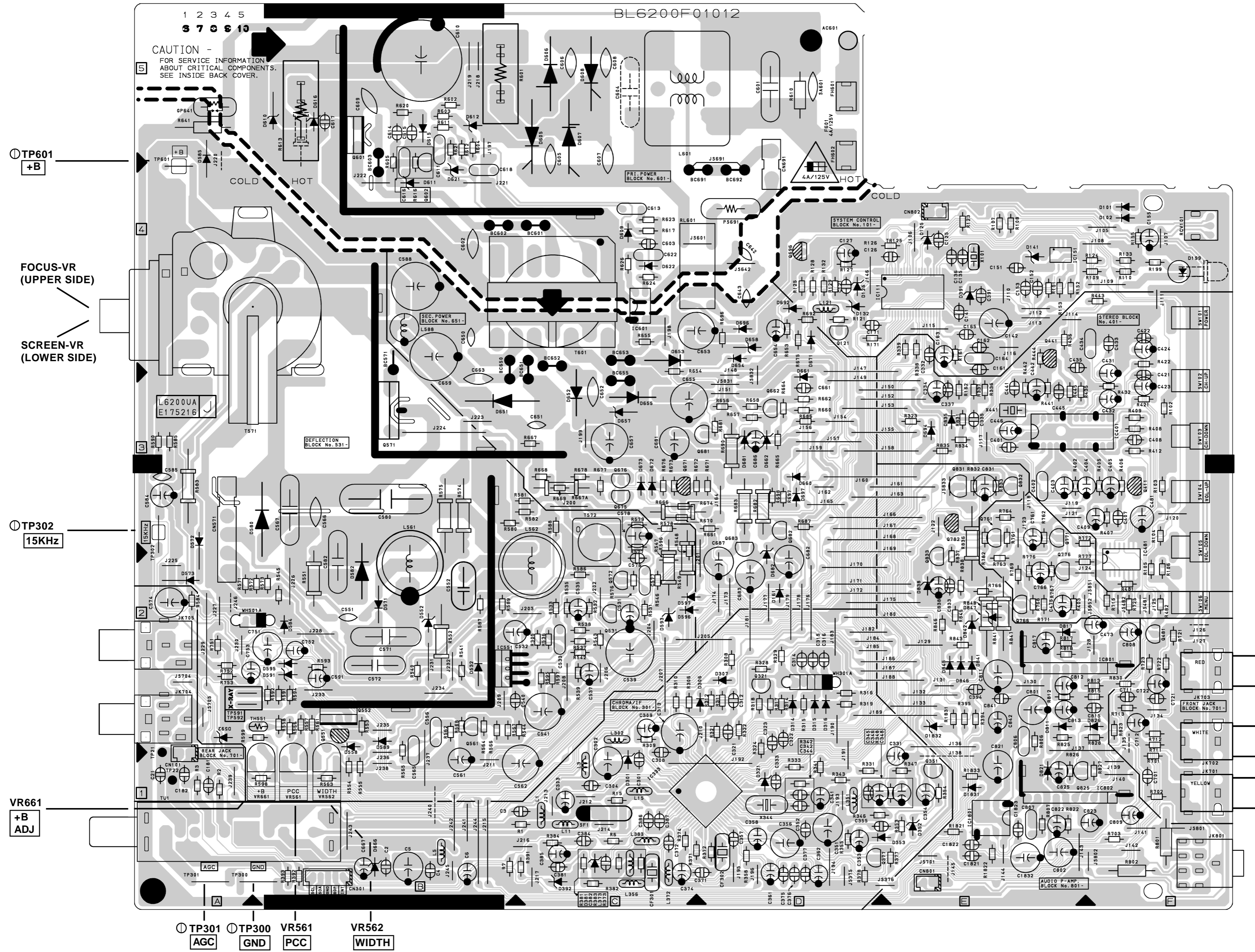

MAIN CBA

Ref No.	Position
ICS	
IC111	D-4
IC151	E-4
IC333	C-1
IC401	F-3
IC551	B-2
IC601	C-4
IC801	F-2
IC802	F-1
TRANSISTORS	
Q121	D-4
Q351	E-1
Q377	E-1
Q411	F-3
Q441	E-4
Q531	C-2
Q551	B-2
Q552	B-2
Q561	B-2
Q571	B-3
Q572	C-2
Q601	B-5
Q602	B-4
Q662	D-3
Q671	C-3
Q675	C-3
Q681	D-3
Q682	D-3
Q683	D-3
Q696	D-4
Q825	E-1
Q831	E-3
Q832	E-3
Q833	E-2
TEST POINTS	
TP300	A-1
TP301	A-1
TP302	A-2
TP591	A-2
TP592	A-2
TP601	A-5
CONNECTORS	
CN301	B-1
CN571	A-3
CN691	D-4
CN801	E-1
CN802	E-4
WH301A	D-2
WH501A	A-2
VARIABLE RESISTORS	
VR561	B-1
VR562	B-1
VR661	A-1

Main CBA Bottom View

**CAUTION!**  
Fixed voltage power supply circuit is used in this unit.  
If Main Fuse (F601) is blown, check to see that all components in the power supply circuit are not defective before you connect the AC plug to the AC power supply.  
Otherwise it may cause some components in the power supply circuit to fail.

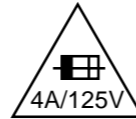

**CAUTION**  
FOR CONTINUED PROTECTION AGAINST FIRE HAZARD,  
REPLACE ONLY WITH THE SAME TYPE FUSE.  
ATTENTION : POUR UNE PROTECTION CONTINUE LES RISQUES  
D'INCELE N'UTILISER QUE DES FUSIBLES DE MEMO TYPE.  
**RISK OF FIRE-REPLACE FUSE AS MARKED.**  
\*This symbol means fast operating fuse.\*  
\*Ce symbole représente un fusible à fusion rapide.\*

**BECAUSE A HOT CHASSIS GROUND IS PRESENT IN THE POWER SUPPLY CIRCUIT, AN ISOLATION TRANSFORMER MUST BE USED. ALSO, IN ORDER TO HAVE THE ABILITY TO INCREASE THE INPUT SLOWLY, WHEN TROUBLESHOOTING THIS TYPE POWER SUPPLY CIRCUIT, A VARIABLE ISOLATION TRANSFORMER IS REQUIRED.**

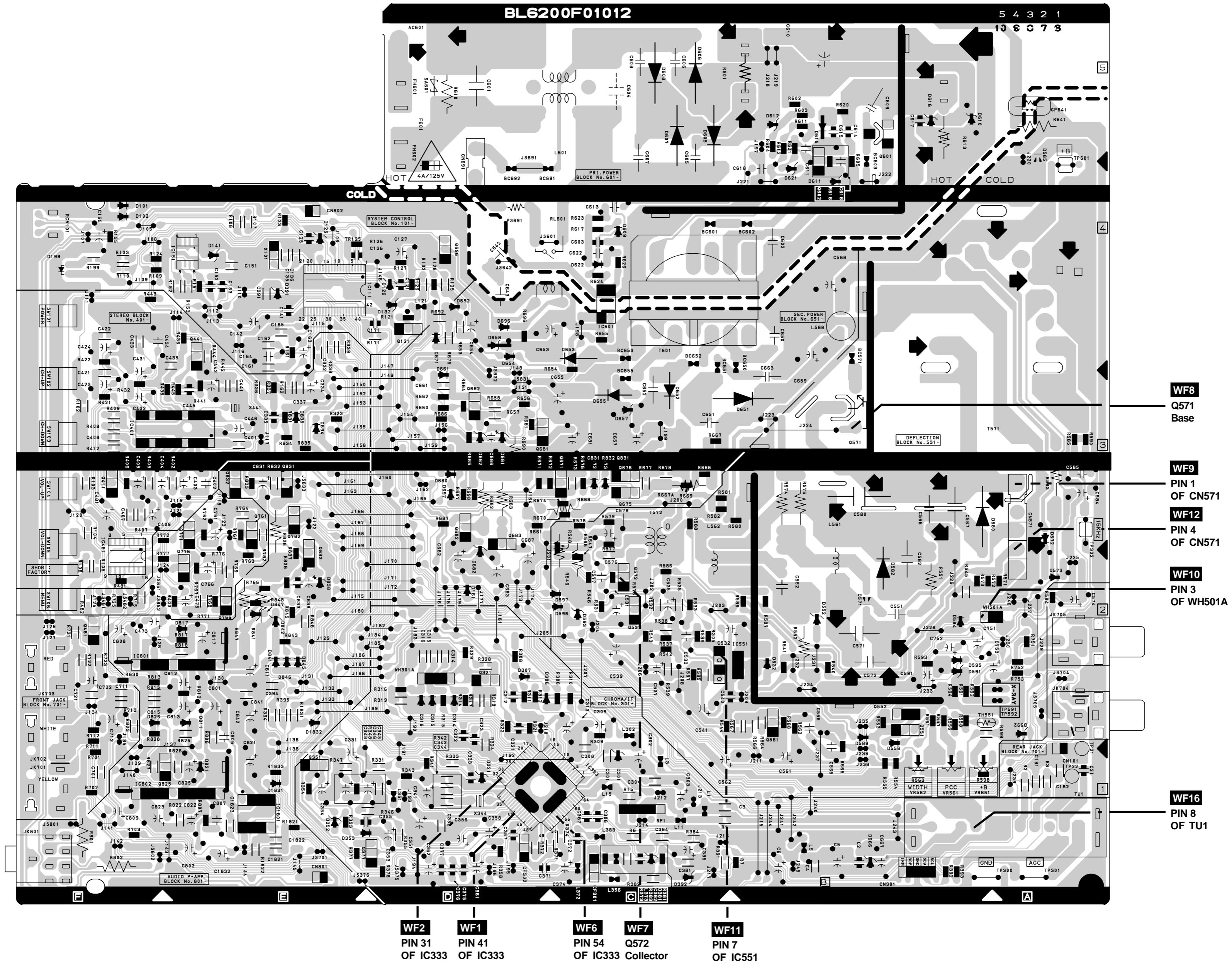

# WAVEFORMS

WF1 ~ WF16 = Waveforms to be observed at Waveform check points. (Shown in Schematic Diagram.)

**Input:** NTSC Color Bar Signal (with 1kHz Audio Signal)  
**INITIAL POSITION:** Unplug unit from AC outlet for at least 5 minutes. reconnect to AC outlet and then turn power on.  
 (Brightness---Center Color---Center Tint --- Center Contrast---Approx 70%)

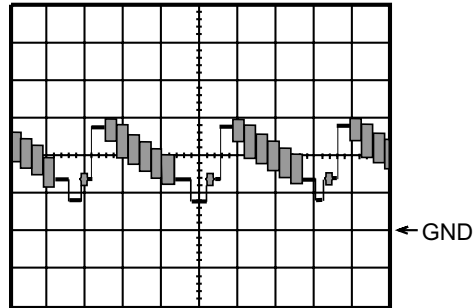

**WF1** 1DIV: 0.5V 20 $\mu$ sec  
IC 333 Pin 41

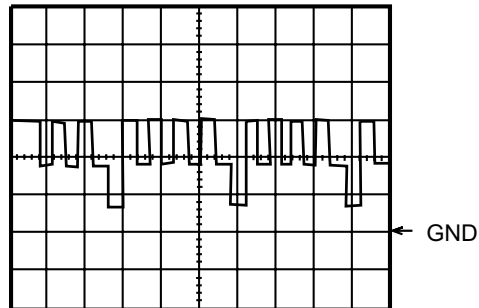

**WF5** 1DIV: 2V 20 $\mu$ sec  
Q 1532 Base

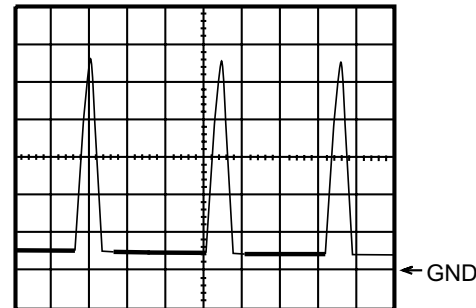

**WF9** 1DIV: 200V 20 $\mu$ sec  
CN 571 Pin 1

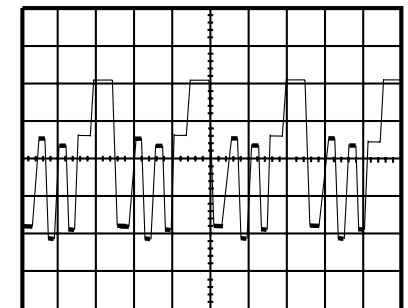

**WF13** 1DIV: 20V 20 $\mu$ sec  
Q1532 Collector

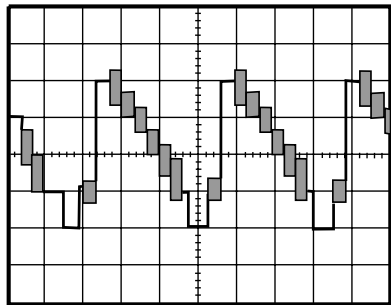

**WF2** 1DIV: 0.5V 20 $\mu$ sec  
IC 333 Pin 31

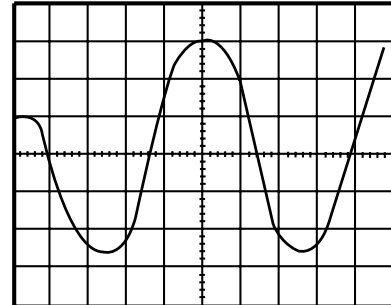

**WF6** 1DIV: 0.2V 20msec  
IC 333 Pin 54

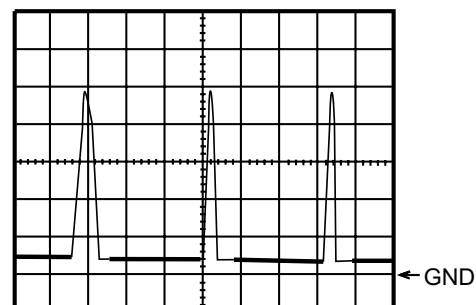

**WF10** 1DIV: 5V 20 $\mu$ sec  
WH501A Pin 1

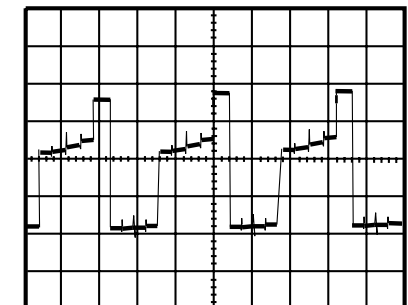

**WF14** 1DIV: 20V 20 $\mu$ sec  
Q 1522 Collector

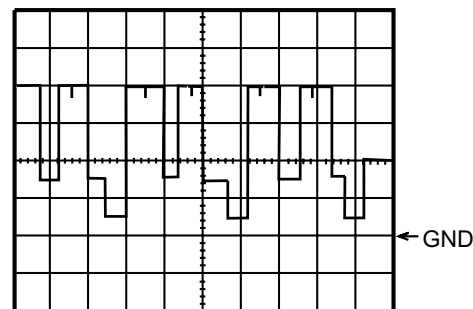

**WF3** 1DIV: 2V 20 $\mu$ sec  
Q1512 Base

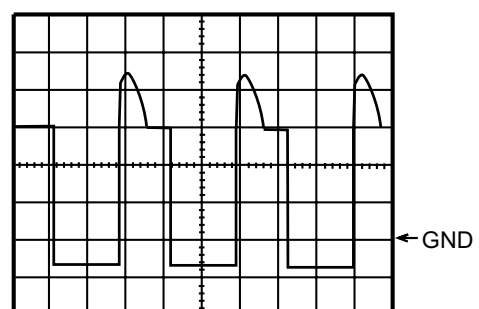

**WF7** 1DIV: 10V 20 $\mu$ sec  
Q 572 Collector

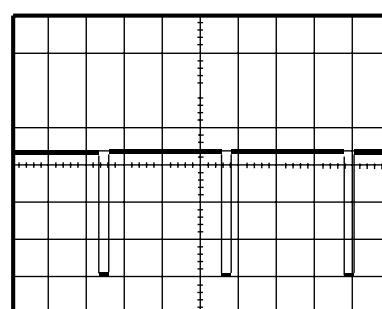

**WF11** 1DIV: 2V 5msec  
IC 551 Pin 7

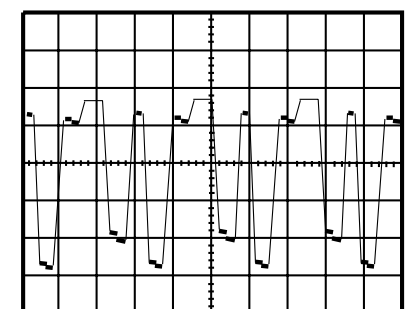

**WF15** 1DIV: 20V 20 $\mu$ sec  
Q 1512 Collector

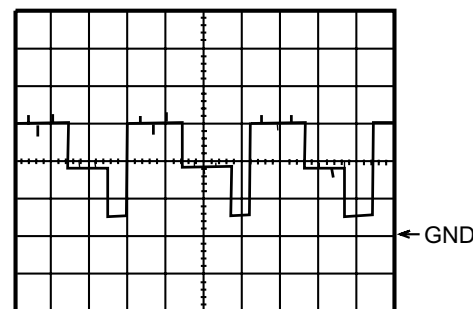

**WF4** 1DIV: 2V 20 $\mu$ sec  
Q 1522 Base

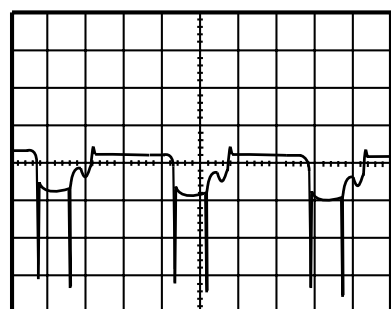

**WF8** 1DIV: 5V 20 $\mu$ sec  
Q 571 Base

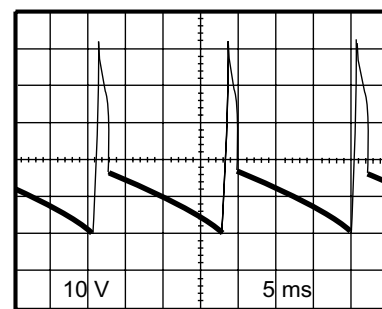

**WF12** 1DIV: 10V 5msec  
CN 571 Pin 4

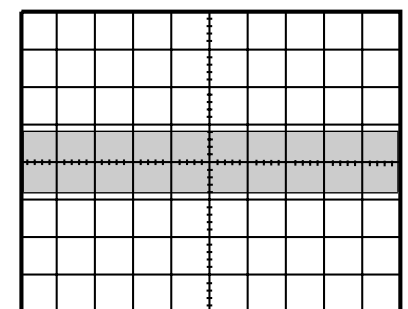

**WF16** 1DIV: 0.2V 20 $\mu$ sec  
TU 1 Pin 8



# WIRING DIAGRAM

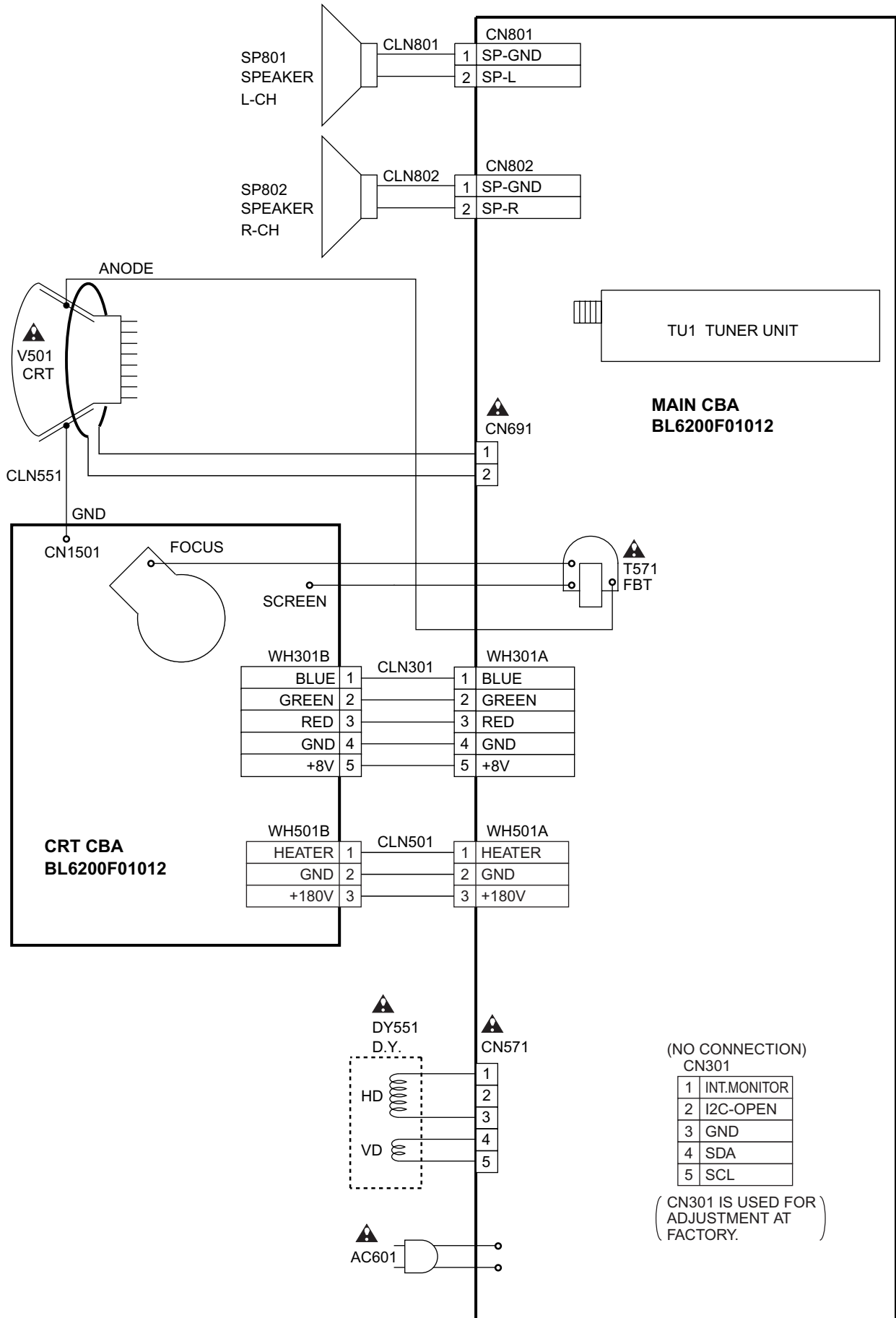

# IC PIN FUNCTIONS

## IC111(TV Micro Computer)

Pin No.	Signal Name	Function
1	N.U.	Not Used
2	VOLUME	Volume
3	EXT-H	Ext-H
4	N.U.	Not Used
5	KEY-IN 1	Key Input 1 (Main)
6	PROTECT-2	Power Supply Protection
7	PROTECT-1	Power Supply Protection
8	KEY-IN 2	Key Input 2 (Main)
9	RCV-IN	Input For Remote Control
10	A-MUTE	Audio Mute
11	DG-ON-H	Degaussing Coil Control
12	MONO-OUT	MONO-OUT
13	PROTECT-3	Power Supply Protection
14	N.U.	Not Used
15	N.U.	Not Used
16	N.U.	Not Used
17	N.U.	Not Used
18	GND	GND
19	N.U.	Not Used
20	N.U.	Not Used
21	GND	GND
22	VCC	+5V
23	FILT	PLL Filter
24	HLF	Filter for CCD
25	VHOLD	VHOLD
26	CVIN	Input for Video Signal
27	RESET	RESET
28	FSC-IN	External Clock Input
29	P-ON-H	Output for P-ON-H
30	SCL	I2C-BUS ControllerInterface (Clock)
31	SDA	I2C-BUS ControllerInterface (Data)
32	CLK-CTRL	Clock Control Signal
33	OSD-BLK	Picture Shut Down Output
34	OSD-R	Red Output

Pin No.	Signal Name	Function
35	OSD-G	Green Output
36	OSD-B	Blue Output
37	V-SYNC	Input For Vertical Synchronize Signal
38	H-SYNC	Input For Horizontal Synchronize Signal
39	INT-MONI/ SD	Intelligent Monitor/ Detection SD signal
40	STEREO-IN	STEREO-IN
41	N.U.	Not Used
42	I2C-OPEN	White Balance Adjustment Judgement



# Packing

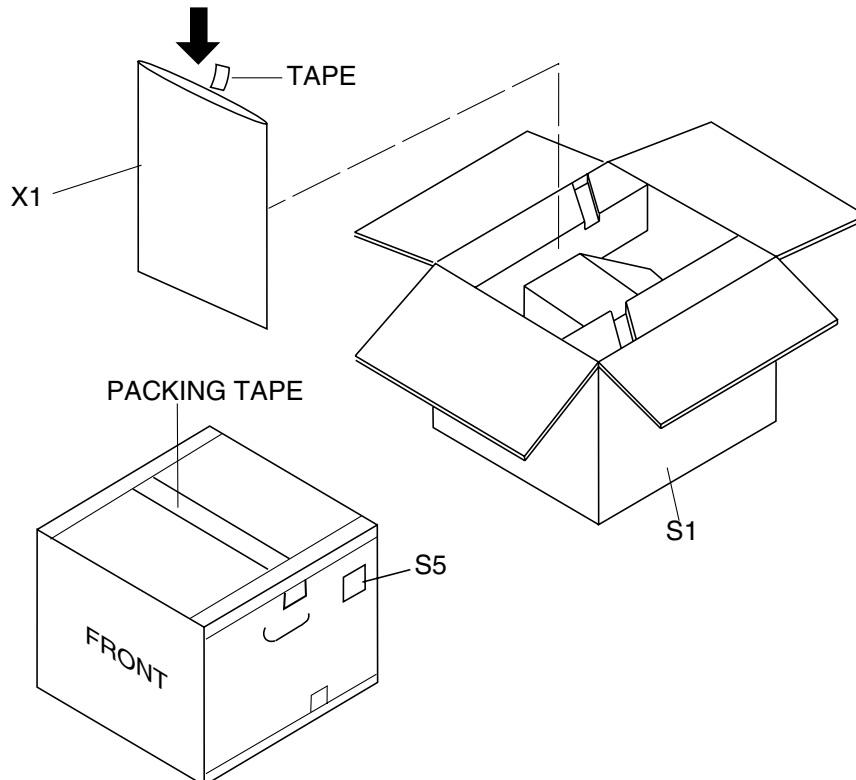
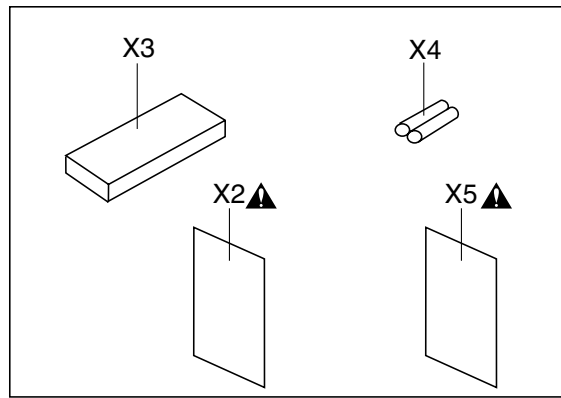
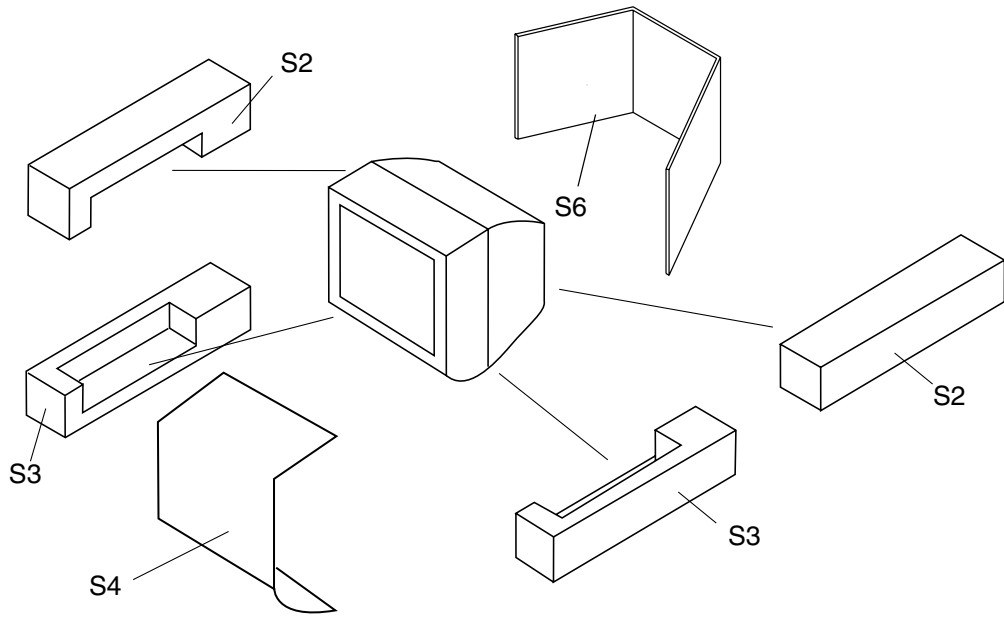

# MECHANICAL PARTS LIST

**PRODUCT SAFETY NOTE:** Products marked with a ▲ have special characteristics important to safety. Before replacing any of these components, read carefully the product safety notice in this service manual. Don't degrade the safety of the product through improper servicing.

**NOTE:**

Parts that are not assigned part numbers (-----) are not available.

Ref. No.	Description	Part No.
A1	FRONT CABINET L6202CC	0EM101195
A2	CONTROL PLATE L6202CC	0EM301659
A4	REAR CABINET L1201CB	0EM101064
A5▲	RATING LABEL L6202CC	-----
B1	TENSION SPRING B0080B0:EM40808	26VH006
B2▲	M7 CRT SCREW(D22) T7205UF	0EM406573
B3▲	DEGAUSS HOLDER L1200UA	0EM405869
B4	SPEAKER HOLDER L1200UA	0EM405691
B5	CLOTH L9800UA:95X15XT:0.5	0EM405041
B6	CLOTH(10X30XT1.0) L9814UQ	0EM405137
B7▲	CRITICAL PARTS WARNING LABEL B8007C3:EM41210	24LH199
CLN551	CRT GND WIRE CRT GND	WX1L1200-007
CLN801	WIRE ASSEMBLY SPEAKER WIRE(180MM)	WX1L9800-001
CLN802	WIRE ASSEMBLY SPEAKER WIRE(180MM)	WX1L1131-001
DG691▲	DEGAUSSING COIL F-029 or	LLBH00ZTM029
▲	DEGAUSSING COIL AVDG122	LLBH00ZWR043
L1	SCREW, P-TIGHT 3X12 BIND HEAD+	GBMP3120
L2	SCREW, P-TIGHT 4X18 BIND HEAD +	GBMP4180
L3	SCREW TAPPING M4X14	DBU14140
L4	SCREW, P-TIGHT 3X10 BIND HEAD+	GBKP3100
SP801	SPEAKER S08N04	DSD0808XQ013
SP802	SPEAKER S08N04	DSD0808XQ013
<b>PACKING</b>		
S1	CARTON L6202CC	0EM407284
S2	STYROFOAM TOP ASSEMBLY L6201UB	0EM407225
S3	STYROFOAM BOTTOM ASSEMBLY L6201UB	0EM407226
S4	SET SHEET PCEC:003502019816	0EM403887
S5	SERIAL NO. LABEL L6202CC	0EM407285
S6	HOLD PAD L6201UB	0EM407287
<b>ACCESSORIES</b>		
X1	POLYETHYLENE BAG F8626B5	Z325350
X2▲	OWNER'S MANUAL L6202CC:ENGLISH/SPANISH	0EMN01948
X3	REMOCON UNIT 130/ERC001/N0132UD or	N0132UD
	REMOCON UNIT 130/ERC001/N0108UD	N0108UD
X4	DRY BATTERY R6P UM3 or	XB0M451GH001
	DRY BATTERY R6P/2S or	XB0M451T0001
	DRY BATTERY(SUNRISE) R6SSE/2S or	XB0M451MS002
	DRY BATTERY R6P(AR)2PX or	XB0M451HU002
	DRY BATTERY R6P(AR)2P X ICI	XB0M451HU003
X5▲	QUICK SETUP GUIDE L1004CE	0EMN01726
<b>Note:</b> 1. V501 (CRT) HAS SUBSTITUTIONAL PARTS AND EACH PART. ALSO HAS A MATCHING COMBINATION WITH DY551. PLEASE SEE TABLE 1 FOR DETAILS OF MATCHING COMBINATION. 2. DY551 (DEFLECTION YOKE) HAS A MATCHING COMBINATION WITH V501. PLEASE SEE TABLE 1 FOR DETAILS OF MATCHING COMBINATION.		

Ref. No.	Description	Part No.
<b>CRT TYPE A</b>		
DY551▲	DEFLECTION YOKE ODY-C29029	LLBY00ZQS006
V501▲	CRT A68KTB359X(B) or	TCRT190QS024
▲	CRT A68KTB359X(PB) or	TCRT190QS025
▲	CRT A68KTB259X2 or	TCRT190QS021
▲	CRT A68KTB259X(P)	TCRT190QS023
V501-1	PCM JH88DTA	XM04000BV010
V501-2	WEDGE FT-00110W or	XV10000T4001
	WEDGE DB25SR	XV10000D9001
<b>CRT TYPE B</b>		
DY551▲	DEFLECTION YOKE CDY-F2927H	LLBY00ZQS014
V501▲	CRT A68QBT892X	TCRT190SM028
V501-1	PCM JH88DTA	XM04000BV010
V501-2	WEDGE FT-00110W or	XV10000T4001
	WEDGE DB25SR	XV10000D9001

**Table 1 (V501 and DY551 Combination)**

**Note 1:** Purity and Convergence Adjustments must be performed following CRT replacement. Refer to Electrical Adjustment Instructions.

**Note 2:** Please confirm CRT Type No. on the CRT Warning Label which is located on the CRT. Then see Table 1 for V501 and DY551 combination chart.

Please refer to this CRT, Deflection Yoke combination chart for parts order.

V501: CRT Type No.	V501: CRT Part No.	DY551: Deflection Yoke Part No.
CRT A68KTB359X(B)	TCRT190QS024	LLBY00ZQS006
CRT A68KTB359X(PB)	TCRT190QS025	
CRT A68KTB259X2	TCRT190QS021	
CRT A68KTB259X(P)	TCRT190QS023	
CRT A68QBT892X	TCRT190SM028	LLBY00ZQS014

## CRT Warning Label Location

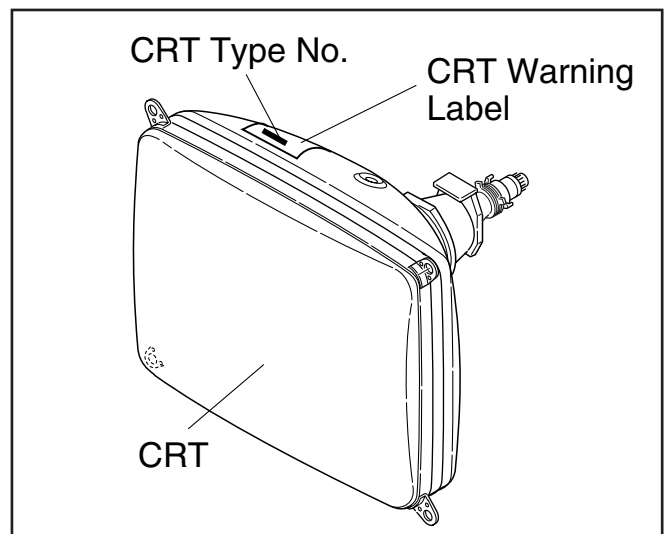

# ELECTRICAL PARTS LIST

**PRODUCT SAFETY NOTE:** Products marked with a **▲** have special characteristics important to safety. Before replacing any of these components, read carefully the product safety notice in this service manual. Don't degrade the safety of the product through improper servicing.

## NOTES:

- Parts that are not assigned part numbers (-----) are not available.
- Tolerance of Capacitors and Resistors are noted with the following symbols.

C.....±0.25%    D.....±0.5%    F.....±1%  
 G.....±2%    J.....±5%    K.....±10%  
 M.....±20%    N.....±30%    Z.....+80/-20%

## MMA-378 CBA

Ref. No.	Description	Part No.
	MMA-378 CBA	0ESA04799
	Consists of the following	
	MAIN CBA	-----
	CRT CBA	-----

## MAIN CBA

Ref. No.	Description	Part No.
	MAIN CBA	-----
	Consists of the following	
<b>CAPACITORS</b>		
C2	CERAMIC CAP.(AX) F Z 0.01µF/50V or	CA1J103TU014
	CERAMIC CAP. YV Z 0.01µF/50V or	CCD1JZSYV103
	CERAMIC CAP. F Z 0.01µF/50V	CCD1JZSOF103
C4	CERAMIC CAP.(AX) F Z 0.01µF/25V	CDA1EZT0F103
C5	ELECTROLYTIC CAP. 100µF/10V M or	CE1AMASTL101
	ELECTROLYTIC CAP. 100µF/10V M	CE1AMASDL101
C6	ELECTROLYTIC CAP. 4.7µF/50V M or	CE1JMASTL4R7
	ELECTROLYTIC CAP. 4.7µF/50V M	CE1JMASDL4R7
C125	CERAMIC CAP.(AX) Y K 0.01µF/16V	CDA1CKT0Y103
C126	CERAMIC CAP.(AX) F Z 0.01µF/25V	CDA1EZT0F103
C127	ELECTROLYTIC CAP. 3.3µF/50V M or	CE1JMASTL3R3
	ELECTROLYTIC CAP. 3.3µF/50V M	CE1JMASDL3R3
C135	PCB JUMPER D0.6-P5.0	JW5.0T
C141	CERAMIC CAP.(AX) F Z 0.01µF/25V	CDA1EZT0F103
C142	ELECTROLYTIC CAP. 100µF/10V M or	CE1AMASTL101
	ELECTROLYTIC CAP. 100µF/10V M	CE1AMASDL101
C151	CERAMIC CAP.(AX) F Z 0.01µF/25V	CDA1EZT0F103
C152	CERAMIC CAP.(AX) B K 100pF/50V	CCA1JKT0B101
C153	CERAMIC CAP.(AX) B K 100pF/50V	CCA1JKT0B101
C155	ELECTROLYTIC CAP. 47µF/16V M or	CE1CMASL470
	ELECTROLYTIC CAP. 47µF/16V M	CE1CMASDL470
C161	CERAMIC CAP.(AX) Y K 0.01µF/16V	CDA1CKT0Y103
C162	CERAMIC CAP.(AX) B K 220pF/50V	CCA1JKT0B221
C163	ELECTROLYTIC CAP. 0.1µF/50V M or	CE1JMASTLR10
	ELECTROLYTIC CAP. 0.1µF/50V M or	CE1JMASDLR10

Ref. No.	Description	Part No.
	ELECTROLYTIC CAP. 0.1µF/50V M	CE1JMASDL0R1
C164	FILM CAP.(P) 0.001µF/50V J or	CMA1JJS00102
	FILM CAP.(P) 0.001µF/50V J	CA1J102MS029
C165	CERAMIC CAP.(AX) B K 1000pF/50V	CCA1JKT0B102
C171	CERAMIC CAP.(AX) B K 220pF/50V	CCA1JKT0B221
C302	ELECTROLYTIC CAP. 220µF/10V M or	CE1AMASTL221
	ELECTROLYTIC CAP. 220µF/10V M	CE1AMASDL221
C303	ELECTROLYTIC CAP. 1µF/50V M or	CE1JMASTL1R0
	ELECTROLYTIC CAP. 1µF/50V M or	CE1JMASDL1R0
	ELECTROLYTIC CAP. 1µF/50V M	CE1JMASDL010
C304	CERAMIC CAP.(AX) Y K 0.01µF/16V	CDA1CKT0Y103
C308	CERAMIC CAP.(AX) Y K 0.01µF/16V	CDA1CKT0Y103
C309	ELECTROLYTIC CAP. 1µF/50V M or	CE1JMASTL1R0
	ELECTROLYTIC CAP. 1µF/50V M or	CE1JMASDL1R0
	ELECTROLYTIC CAP. 1µF/50V M	CE1JMASDL010
C313	ELECTROLYTIC CAP. 1000µF/10V M(VR) or	CE1AMZNTL102
	ELECTROLYTIC CAP. 1000µF/10V M or	CE1AMZNDL102
	ELECTROLYTIC CAP. 1000µF/10V M	CE1AMZADL102
C321	CERAMIC CAP.(AX) Y K 0.01µF/16V	CDA1CKT0Y103
C322	CERAMIC CAP.(AX) Y K 0.01µF/16V	CDA1CKT0Y103
C331	ELECTROLYTIC CAP. 47µF/16V M or	CE1CMASL470
	ELECTROLYTIC CAP. 47µF/16V M	CE1CMASDL470
C332	CERAMIC CAP.(AX) B K 1000pF/50V	CCA1JKT0B102
C334	ELECTROLYTIC CAP. 4.7µF/50V M or	CE1JMASTL4R7
	ELECTROLYTIC CAP. 4.7µF/50V M	CE1JMASDL4R7
C335	CERAMIC CAP.(AX) F Z 0.1µF/50V or	CA1J104TU014
	CERAMIC CAP.(AX) F Z 0.1µF/50V	CCA1JZT0F104
C337	CERAMIC CAP.(AX) B K 470pF/50V	CCA1JKT0B471
C341	ELECTROLYTIC CAP. 1µF/50V M or	CE1JMASTL1R0
	ELECTROLYTIC CAP. 1µF/50V M or	CE1JMASDL1R0
	ELECTROLYTIC CAP. 1µF/50V M	CE1JMASDL010
C342	CERAMIC CAP.(AX) F Z 0.1µF/50V or	CA1J104TU014
	CERAMIC CAP.(AX) F Z 0.1µF/50V	CCA1JZT0F104
C344	CERAMIC CAP.(AX) B K 1000pF/50V	CCA1JKT0B102
C345	CERAMIC CAP.(AX) Y M 0.015µF/6V	CDA0KMT0Y153
C346	ELECTROLYTIC CAP. 1µF/50V M or	CE1JMASTL1R0
	ELECTROLYTIC CAP. 1µF/50V M or	CE1JMASDL1R0
	ELECTROLYTIC CAP. 1µF/50V M	CE1JMASDL010
C348	ELECTROLYTIC CAP. 0.1µF/50V M or	CE1JMASTLR10
	ELECTROLYTIC CAP. 0.1µF/50V M or	CE1JMASDLR10
	ELECTROLYTIC CAP. 0.1µF/50V M	CE1JMASDL0R1
C351	ELECTROLYTIC CAP. 100µF/10V M or	CE1AMASTL101
	ELECTROLYTIC CAP. 100µF/10V M	CE1AMASDL101
C353	ELECTROLYTIC CAP. 10µF/50V M or	CE1JMASTL100
	ELECTROLYTIC CAP. 10µF/50V M	CE1JMASDL100
C354	ELECTROLYTIC CAP. 10µF/50V M or	CE1JMASTL100
	ELECTROLYTIC CAP. 10µF/50V M	CE1JMASDL100
C355	CERAMIC CAP.(AX) F Z 0.01µF/25V	CDA1EZT0F103
C356	ELECTROLYTIC CAP. 470µF/10V M or	CE1AMASTL471
	ELECTROLYTIC CAP. 470µF/10V M	CE1AMASDL471
C358	ELECTROLYTIC CAP. 0.47µF/50V M or	CE1JMASTLR47
	ELECTROLYTIC CAP. 0.47µF/50V M	CE1JMASDLR47
C361	ELECTROLYTIC CAP. 1µF/50V M or	CE1JMASTL1R0
	ELECTROLYTIC CAP. 1µF/50V M or	CE1JMASDL1R0
	ELECTROLYTIC CAP. 1µF/50V M	CE1JMASDL010
C371	CERAMIC CAP.(AX) SL J 47pF/50V	CCA1JUTSL470
C372	CERAMIC CAP.(AX) SL J 47pF/50V	CCA1JUTSL470

Ref. No.	Description	Part No.
C374	ELECTROLYTIC CAP. 2.2μF/50V M LL or	CE1JMASLL2R2
	ELECTROLYTIC CAP. 2.2μF/50V LL	CE1JMASLH2R2
C375	PCB JUMPER D0.6-P5.0	JW5.0T
C381	CERAMIC CAP.(AX) F Z 0.1μF/50V or	CA1J104TU014
	CERAMIC CAP.(AX) F Z 0.1μF/50V	CCA1JZT0F104
C382	CERAMIC CAP.(AX) F Z 0.01μF/25V	CDA1EZT0F103
C384	CERAMIC CAP.(AX) CH J 68pF/50V	CA1J680TU008
C385	ELECTROLYTIC CAP. 0.47μF/50V M or	CE1JMASTLR47
	ELECTROLYTIC CAP. 0.47μF/50V M	CE1JMASDLR47
C386	CERAMIC CAP.(AX) B K 0.047μF/50V	CA1J473TU011
C387	CERAMIC CAP.(AX) B K 0.047μF/50V	CA1J473TU011
C391	CERAMIC CAP.(AX) F Z 0.1μF/50V or	CA1J104TU014
	CERAMIC CAP.(AX) F Z 0.1μF/50V	CCA1JZT0F104
C401	CERAMIC CAP.(AX) X K 4700pF/16V	CDA1CKT0X472
C402	MYLAR CAP. 0.22μF/50V J or	CMA1JJS00224
	FILM CAP.(P) 0.22μF/50V J	CA1J224MS029
C403	ELECTROLYTIC CAP. 1μF/50V M or	CE1JMASTL1R0
	ELECTROLYTIC CAP. 1μF/50V M or	CE1JMASDL1R0
	ELECTROLYTIC CAP. 1μF/50V M	CE1JMASDL010
C404	ELECTROLYTIC CAP. 0.1μF/50V M or	CE1JMASTLR10
	ELECTROLYTIC CAP. 0.1μF/50V M or	CE1JMASDLR10
	ELECTROLYTIC CAP. 0.1μF/50V M	CE1JMASDL0R1
C405	ELECTROLYTIC CAP. 47μF/16V M or	CE1CMASL470
	ELECTROLYTIC CAP. 47μF/16V M	CE1CMASDL470
C408	CERAMIC CAP.(AX) F Z 0.1μF/50V or	CA1J104TU014
	CERAMIC CAP.(AX) F Z 0.1μF/50V	CCA1JZT0F104
C409	ELECTROLYTIC CAP. 1μF/50V M or	CE1JMASTL1R0
	ELECTROLYTIC CAP. 1μF/50V M or	CE1JMASDL1R0
	ELECTROLYTIC CAP. 1μF/50V M	CE1JMASDL010
C421	CERAMIC CAP.(AX) X K 2700pF/16V	CDA1CKT0X272
C422	CERAMIC CAP.(AX) X K 2700pF/16V	CDA1CKT0X272
C423	PCB JUMPER D0.6-P5.0	JW5.0T
C424	PCB JUMPER D0.6-P5.0	JW5.0T
C431	ELECTROLYTIC CAP. 2.2μF/50V M or	CE1JMASTL2R2
	ELECTROLYTIC CAP. 2.2μF/50V M	CE1JMASDL2R2
C432	ELECTROLYTIC CAP. 10μF/50V M or	CE1JMASTL100
	ELECTROLYTIC CAP. 10μF/50V M	CE1JMASDL100
C433	CERAMIC CAP.(AX) X K 2700pF/16V	CDA1CKT0X272
C434	FILM CAP.(P) 0.1μF/50V J or	CMA1JJS00104
	FILM CAP.(P) 0.1μF/50V J	CA1J104MS029
C435	CERAMIC CAP.(AX) F Z 0.01μF/25V	CDA1EZT0F103
C441	CERAMIC CAP.(AX) F Z 0.01μF/25V	CDA1EZT0F103
C442	ELECTROLYTIC CAP. 10μF/50V M or	CE1JMASTL100
	ELECTROLYTIC CAP. 10μF/50V M	CE1JMASDL100
C446	ELECTROLYTIC CAP. 1μF/50V M or	CE1JMASTL1R0
	ELECTROLYTIC CAP. 1μF/50V M or	CE1JMASDL1R0
	ELECTROLYTIC CAP. 1μF/50V M	CE1JMASDL010
C473	ELECTROLYTIC CAP. 10μF/50V M or	CE1JMASTL100
	ELECTROLYTIC CAP. 10μF/50V M	CE1JMASDL100
C475	ELECTROLYTIC CAP. 10μF/50V M or	CE1JMASTL100
	ELECTROLYTIC CAP. 10μF/50V M	CE1JMASDL100
C481	ELECTROLYTIC CAP. 100μF/16V M or	CE1CMASL101
	ELECTROLYTIC CAP. 100μF/16V M	CE1CMASDL101
C531	ELECTROLYTIC CAP. 22μF/50V M or	CE1JMASTL220
	ELECTROLYTIC CAP. 22μF/50V M	CE1JMASDL220
C532	ELECTROLYTIC CAP. 47μF/35V M or	CE1GMASTL470
	ELECTROLYTIC CAP. 47μF/35V M	CE1GMASDL470
C533	FILM CAP.(P) 0.1μF/50V J or	CMA1JJS00104
	FILM CAP.(P) 0.1μF/50V J	CA1J104MS029
C535	ELECTROLYTIC CAP. 1.5μF/50V M LL	CE1JMASLL1R5
C539▲	ELECTROLYTIC CAP. 1000μF/25V M or	CE1EMZNTL102

Ref. No.	Description	Part No.
▲	ELECTROLYTIC CAP. 1000μF/25V M or	CE1EMZPDL102
▲	ELECTROLYTIC CAP. 1000μF/25V M	CE1EMZADL102
C541	ELECTROLYTIC CAP. 470μF/35V M(VR) or	CE1GMZNTL471
	ELECTROLYTIC CAP. 470μF/35V M or	CE1GMZADL471
	ELECTROLYTIC CAP. 470μF/35V M	CE1GMZNDL471
C551▲	PCB JUMPER D0.6-P10.0	JW10.0T
C552▲	METALIZED PLYESTER CAP. 1μF/100V J	CT2A105MS065
C556	FILM CAP.(P) 0.1μF/50V J or	CMA1JJS00104
	FILM CAP.(P) 0.1μF/50V J	CA1J104MS029
C561	ELECTROLYTIC CAP. 47μF/35V M or	CE1GMASTL470
	ELECTROLYTIC CAP. 47μF/35V M	CE1GMASDL470
C562	ELECTROLYTIC CAP. 470μF/25V M or	CE1EMZNTL471
	ELECTROLYTIC CAP. 470μF/25V M or	CE1EMZNDL471
	ELECTROLYTIC CAP. 470μF/25V M	CE1EMZADL471
C565	FILM CAP.(P) 0.1μF/50V J or	CMA1JJS00104
	FILM CAP.(P) 0.1μF/50V J	CA1J104MS029
C566	CERAMIC CAP. LB 560pF/2KV or	CA3D561KG004
	CERAMIC CAP. BN 560pF/2KV or	CCD3DKA0B561
	CERAMIC CAP. 560pF/2KV	CA3D561PAN04
C567▲	PP CAP. 0.0027μF/1.6KV J or	CA3C272VC010
▲	PP CAP. 0.0027μF/1.6KV J	CT3C272MS039
C571▲	P.P.CAP 0.47μF/200 J or	CA2D474VC012
▲	PP CAP. 0.47μF/250V J	CT2E474MS041
C574	ELECTROLYTIC CAP. 4.7μF/250V M	CE2EMASDL4R7
C577	FILM CAP.(P) 0.01μF/50V J or	CMA1JJS00103
	FILM CAP.(P) 0.01μF/50V J	CA1J103MS029
C578	ELECTROLYTIC CAP. 47μF/35V M or	CE1GMASTL470
	ELECTROLYTIC CAP. 47μF/35V M	CE1GMASDL470
C580▲	PP CAP. 0.015μF/1.6KV J or	CA3C153VC010
▲	PP CAP. 0.015μF/1.6KV J	CT3C153MS039
C582▲	P.P. CAP. 0.022μF/200V J or	CA2D223VC013
▲	P.P. CAP. 0.022μF/200V K	CBP2DKD00223
C584▲	ELECTROLYTIC CAP. 1μF/160V M or	CE2CMASL1R0
▲	ELECTROLYTIC CAP. 1μF/160V M	CE2CMASDL1R0
C585	CERAMIC CAP. B K 100pF/500V	CCD2JKS0B101
C588	ELECTROLYTIC CAP. 100μF/160V M or	CE2CMZPTL101
	ELECTROLYTIC CAP. 100μF/160V M	CE2CMZNDL101
C591▲	ELECTROLYTIC CAP. 10μF/50V M or	CE1JMASTL100
▲	ELECTROLYTIC CAP. 10μF/50V M	CE1JMASDL100
C601▲	METALLIZED FILM CAP. 0.1μF/250V or	CT2E104MS037
▲	FILM CAP.(MP) 0.1μF/250V M or	CT2E104DC009
▲	FILM CAP.(MP) 0.1μF/250V K	CT2E104DC011
C603	CERAMIC CAP.(AX) B K 470pF/50V	CCA1JKT0B471
C605	CERAMIC CAP. F Z 0.01μF/500V or	CCD2JZP0F103
	CERAMIC CAP. 0.01μF/AC250V	CCD2EZA0F103
C606	CERAMIC CAP. F Z 0.01μF/500V or	CCD2JZP0F103
	CERAMIC CAP. 0.01μF/AC250V	CCD2EZA0F103
C609	CERAMIC CAP. B K 1000pF/2KV or	CCD3DKD0B102
	CERAMIC CAP. B K 1000pF/2KV or	CCD3DKP0B102
	CERAMIC CAP. 1000pF/2KV	CA3D102PAN04
C610▲	ELECTROLYTIC CAP. 470μF/200V or	CA2D471NC013
▲	ELECTROLYTIC CAP. 470μF/200V M	CE2DMZNDL471
C611	FILM CAP.(P) 0.0056μF/50V J or	CMA1JJS00562
	FILM CAP.(P) 0.0056μF/50V J	CA1J562MS029
C613	FILM CAP.(P) 0.056μF/50V J or	CMA1JJS00563
	FILM CAP.(P) 0.056μF/50V J	CA1J563MS029
C614	CERAMIC CAP.(AX) X K 2700pF/16V	CDA1CKT0X272
C615	CERAMIC CAP.(AX) B K 100pF/50V	CCA1JKT0B101
C616	FILM CAP.(P) 0.1μF/50V J or	CMA1JJS00104
	FILM CAP.(P) 0.1μF/50V J	CA1J104MS029
C618	FILM CAP.(P) 0.1μF/50V J or	CMA1JJS00104

Ref. No.	Description	Part No.
	FILM CAP.(P) 0.1µF/50V J	CA1J104MS029
<b>If C643 is 4700pF, then JS642 (PCB JUMPER) is used.</b>		
C643▲	SAFETY CAP. 4700pF/250V KX	CA2E472MR050
JS642	PCB JUMPER D0.6-P7.5	JW7.5T
<b>If C642 is 0.01µF, then C643 is 0.01µF.</b>		
C642▲	SAFETY CAP. 10000pF/250V or	CCG2EMA0F103
▲	SAFETY CAP. F M 0.01µF/250V or	CCG2EMP0F103
▲	CERAMIC CAP. 0.01µF F CS	CCG2HMN0F103
C643▲	SAFETY CAP. 10000pF/250V or	CCG2EMA0F103
▲	SAFETY CAP. F M 0.01µF/250V or	CCG2EMP0F103
▲	CERAMIC CAP. 0.01µF F CS	CCG2HMN0F103
C650	CERAMIC CAP. LB 560pF/2KV or	CA3D561KG004
	CERAMIC CAP. BN 560pF/2KV or	CCD3DKA0B561
	CERAMIC CAP. 560pF/2KV	CA3D561PAN04
C651	CERAMIC CAP. LB 560pF/2KV or	CA3D561KG004
	CERAMIC CAP. BN 560pF/2KV or	CCD3DKA0B561
	CERAMIC CAP. 560pF/2KV	CA3D561PAN04
C652	CERAMIC CAP. B K 220pF/2KV or	CCD3DKD0B221
	CERAMIC CAP. B K 220pF/2KV or	CCD3DKP0B221
	CERAMIC CAP. 220pF/2KV	CA3D221PAN04
C653▲	ELECTROLYTIC CAP. 1000µF/16V M(VR/HC) or	CE1CMZNTL102
▲	ELECTROLYTIC CAP. 1000µF/16V M or	CE1CMZPDL102
▲	ELECTROLYTIC CAP. 1000µF/16V M	CE1CMZADL102
C654	ELECTROLYTIC CAP. 1µF/50V M or	CE1JMASTL1R0
	ELECTROLYTIC CAP. 1µF/50V M or	CE1JMASDL1R0
	ELECTROLYTIC CAP. 1µF/50V M	CE1JMASDL010
C655▲	ELECTROLYTIC CAP. 1000µF/16V M(VR/HC) or	CE1CMZNTL102
▲	ELECTROLYTIC CAP. 1000µF/16V M or	CE1CMZPDL102
▲	ELECTROLYTIC CAP. 1000µF/16V M	CE1CMZADL102
C657▲	ELECTROLYTIC CAP. 470µF/35V M(VR) or	CE1GMZNTL471
▲	ELECTROLYTIC CAP. 470µF/35V M or	CE1GMZADL471
▲	ELECTROLYTIC CAP. 470µF/35V M	CE1GMZNDL471
C659▲	ELECTROLYTIC CAP. 100µF/160V M or	CE2CMZPTL101
▲	ELECTROLYTIC CAP. 100µF/160V M	CE2CMZNDL101
C661▲	CERAMIC CAP.(AX) F Z 0.01µF/25V	CDA1EZT0F103
C667	ELECTROLYTIC CAP. 1µF/50V M or	CE1JMASTL1R0
	ELECTROLYTIC CAP. 1µF/50V M or	CE1JMASDL1R0
	ELECTROLYTIC CAP. 1µF/50V M	CE1JMASDL010
C681	ELECTROLYTIC CAP. 100µF/10V M or	CE1AMASTL101
	ELECTROLYTIC CAP. 100µF/10V M	CE1AMASDL101
C682	ELECTROLYTIC CAP. 100µF/10V M or	CE1AMASTL101
	ELECTROLYTIC CAP. 100µF/10V M	CE1AMASDL101
C683	ELECTROLYTIC CAP. 100µF/10V M or	CE1AMASTL101
	ELECTROLYTIC CAP. 100µF/10V M	CE1AMASDL101
C686	ELECTROLYTIC CAP. 33µF/16V M or	CE1CMASTL330
	ELECTROLYTIC CAP. 33µF/16V M	CE1CMASDL330
C687	ELECTROLYTIC CAP. 100µF/10V M or	CE1AMASTL101
	ELECTROLYTIC CAP. 100µF/10V M	CE1AMASDL101
C701	CERAMIC CAP.(AX) B K 100pF/50V	CCA1JKTOB101
C711	CERAMIC CAP.(AX) X K 5600pF/16V	CDA1CKTOX562
C712	ELECTROLYTIC CAP. 0.47µF/50V M or	CE1JMASTLR47
	ELECTROLYTIC CAP. 0.47µF/50V M	CE1JMASDLR47
C721	CERAMIC CAP.(AX) X K 5600pF/16V	CDA1CKTOX562
C722	ELECTROLYTIC CAP. 0.47µF/50V M or	CE1JMASTLR47
	ELECTROLYTIC CAP. 0.47µF/50V M	CE1JMASDLR47
C751	ELECTROLYTIC CAP. 470µF/10V M or	CE1AMASTL471
	ELECTROLYTIC CAP. 470µF/10V M	CE1AMASDL471
C752	ELECTROLYTIC CAP. 0.47µF/50V M or	CE1JMASTLR47
	ELECTROLYTIC CAP. 0.47µF/50V M	CE1JMASDLR47
C753	ELECTROLYTIC CAP. 0.47µF/50V M or	CE1JMASTLR47
	ELECTROLYTIC CAP. 0.47µF/50V M	CE1JMASDLR47

Ref. No.	Description	Part No.
C761	ELECTROLYTIC CAP. 10µF/50V M or	CE1JMASTL100
	ELECTROLYTIC CAP. 10µF/50V M	CE1JMASDL100
C766	ELECTROLYTIC CAP. 10µF/50V M or	CE1JMASTL100
	ELECTROLYTIC CAP. 10µF/50V M	CE1JMASDL100
C801	ELECTROLYTIC CAP. 470µF/16V M or	CE1CMASTL471
	ELECTROLYTIC CAP. 470µF/16V M	CE1CMASDL471
C802	ELECTROLYTIC CAP. 470µF/16V M or	CE1CMASTL471
	ELECTROLYTIC CAP. 470µF/16V M	CE1CMASDL471
C806	FILM CAP.(P) 0.1µF/50V J or	CMA1JJS00104
	FILM CAP.(P) 0.1µF/50V J	CA1J104MS029
C807	FILM CAP.(P) 0.1µF/50V J or	CMA1JJS00104
	FILM CAP.(P) 0.1µF/50V J	CA1J104MS029
C808	ELECTROLYTIC CAP. 10µF/50V M or	CE1JMASTL100
	ELECTROLYTIC CAP. 10µF/50V M	CE1JMASDL100
C809	ELECTROLYTIC CAP. 10µF/50V M or	CE1JMASTL100
	ELECTROLYTIC CAP. 10µF/50V M	CE1JMASDL100
C811	ELECTROLYTIC CAP. 470µF/16V M or	CE1CMASTL471
	ELECTROLYTIC CAP. 470µF/16V M	CE1CMASDL471
C812	ELECTROLYTIC CAP. 47µF/16V M or	CE1CMASTL471
	ELECTROLYTIC CAP. 47µF/16V M	CE1CMASDL470
C813	ELECTROLYTIC CAP. 10µF/50V M or	CE1JMASTL100
	ELECTROLYTIC CAP. 10µF/50V M	CE1JMASDL100
C817	ELECTROLYTIC CAP. 4.7µF/50V M or	CE1JMASTL4R7
	ELECTROLYTIC CAP. 4.7µF/50V M	CE1JMASDL4R7
C821	ELECTROLYTIC CAP. 470µF/16V M or	CE1CMASTL471
	ELECTROLYTIC CAP. 470µF/16V M	CE1CMASDL471
C822	ELECTROLYTIC CAP. 47µF/16V M or	CE1CMASTL470
	ELECTROLYTIC CAP. 47µF/16V M	CE1CMASDL470
C823	ELECTROLYTIC CAP. 10µF/50V M or	CE1JMASTL100
	ELECTROLYTIC CAP. 10µF/50V M	CE1JMASDL100
C825	ELECTROLYTIC CAP. 10µF/50V M or	CE1JMASTL100
	ELECTROLYTIC CAP. 10µF/50V M	CE1JMASDL100
C831	ELECTROLYTIC CAP. 100µF/16V M or	CE1CMASTL101
	ELECTROLYTIC CAP. 100µF/16V M	CE1CMASDL101
C833	CERAMIC CAP.(AX) F Z 0.01µF/25V	CDA1EZT0F103
C838	ELECTROLYTIC CAP. 10µF/50V M or	CE1JMASTL100
	ELECTROLYTIC CAP. 10µF/50V M	CE1JMASDL100
C841	CERAMIC CAP.(AX) F Z 0.01µF/25V	CDA1EZT0F103
<b>CONNECTORS</b>		
CN301	CONNECTOR BASE, 5P TUC-P05P-B1	J3TUA05TG001
CN571▲	CONNECTOR BASE, 5P TV-50P-05-V3 or	J3TVC05TG002
▲	CONNECTOR BASE, 5P RTB-1.5-5P or	J3RTC05JG001
▲	CONNECTOR BASE, 5P W-P3005-02	1730812
CN691▲	CONNECTOR BASE, 2P TV-50P-02-V3 or	J3TVC02TG002
▲	CONNECTOR BASE, 2P RTB-1.5-2P	J3RTC02JG001
CN801	STRAIGHT CONNECTOR BASE 00 8283 0212 00 000 or	J383C02UG002
	STRAIGHT PIN HEADER, 2P 173981-2	1770258
CN802	STRAIGHT CONNECTOR BASE 00 8283 0212 00 000 or	J383C02UG002
	STRAIGHT PIN HEADER, 2P 173981-2	1770258
<b>DIODES</b>		
D101	SWITCHING DIODE 1SS133(T-77) or	QDTZ001SS133
	SWITCHING DIODE 1N4148 or	NDTZ001N4148
	DIODE 1SS176TPA7	1SS176T
D102	SWITCHING DIODE 1SS133(T-77) or	QDTZ001SS133
	SWITCHING DIODE 1N4148 or	NDTZ001N4148
	DIODE 1SS176TPA7	1SS176T
D125	ZENER DIODE MTZJT-775.6B	QDTB0MTZJ5R6
D126▲	ZENER DIODE MTZJT-775.1B	QDTB0MTZJ5R1
D132▲	ZENER DIODE MTZJT-775.1B	QDTB0MTZJ5R1



Ref. No.	Description	Part No.
D141	ZENER DIODE MTZJT-775.6B	QDTB0MTZJ5R6
D161▲	SWITCHING DIODE 1SS133(T-77) or	QDTZ001SS133
▲	SWITCHING DIODE 1N4148 or	NDTZ001N4148
▲	DIODE 1SS176TPA7	1SS176T
D301	ZENER DIODE MTZJT-775.6B	QDTB0MTZJ5R6
D306	SWITCHING DIODE 1SS133(T-77) or	QDTZ001SS133
	SWITCHING DIODE 1N4148 or	NDTZ001N4148
	DIODE 1SS176TPA7	1SS176T
D307	PCB JUMPER D0.6-P5.0	JW5.0T
D314	SWITCHING DIODE 1SS133(T-77) or	QDTZ001SS133
	SWITCHING DIODE 1N4148 or	NDTZ001N4148
	DIODE 1SS176TPA7	1SS176T
D315	SWITCHING DIODE 1SS133(T-77) or	QDTZ001SS133
	SWITCHING DIODE 1N4148 or	NDTZ001N4148
	DIODE 1SS176TPA7	1SS176T
D316	SWITCHING DIODE 1SS133(T-77) or	QDTZ001SS133
	SWITCHING DIODE 1N4148 or	NDTZ001N4148
	DIODE 1SS176TPA7	1SS176T
D321	ZENER DIODE MTZJT-775.6B	QDTB0MTZJ5R6
D352	ZENER DIODE MTZJT-779.1B	QDTB0MTZJ9R1
D353	SWITCHING DIODE 1SS133(T-77) or	QDTZ001SS133
	SWITCHING DIODE 1N4148 or	NDTZ001N4148
	DIODE 1SS176TPA7	1SS176T
D381	ZENER DIODE MTZJT-775.6B	QDTB0MTZJ5R6
D391	ZENER DIODE MTZJT-775.6B	QDTB0MTZJ5R6
D532	DIODE 1N5397-B or	NDLZ001N5397
	RECTIFIER DIODE ERA15-02	AERA1502****
D552▲	ZENER DIODE MTZJT-7715B	QDTB00MTZJ15
D558	SWITCHING DIODE 1SS133(T-77) or	QDTZ001SS133
	SWITCHING DIODE 1N4148 or	NDTZ001N4148
	DIODE 1SS176TPA7	1SS176T
D571	DIODE FR104-B or	NDLZ000FR104
	RECTIFIER DIODE ERA22-02 or	QDPZ0ERA2202
	RECTIFIER DIODE 10ELS2	QDQZ0010ELS2
D572▲	DIODE FR104-B or	NDLZ000FR104
▲	RECTIFIER DIODE ERA22-02 or	QDPZ0ERA2202
▲	RECTIFIER DIODE 10ELS2	QDQZ0010ELS2
D573▲	DIODE FR104-B or	NDLZ000FR104
▲	RECTIFIER DIODE ERA22-02 or	QDPZ0ERA2202
▲	RECTIFIER DIODE 10ELS2	QDQZ0010ELS2
D580▲	DIODE ERD07-15L	QD4ZERD0715L
D582▲	FAST RECOVERY DIODE ERD38-06 or	QDQZ0ERD3806
▲	FAST RECOVERY DIODE 20NFA60	QDAZ020NFA60
D584▲	SWITCHING DIODE 1SS133(T-77) or	QDTZ001SS133
▲	SWITCHING DIODE 1N4148 or	NDTZ001N4148
▲	DIODE 1SS176TPA7	1SS176T
D585	DIODE 1N5397-B or	NDLZ001N5397
	RECTIFIER DIODE ERA15-02	AERA1502****
D589	SWITCHING DIODE 1SS133(T-77) or	QDTZ001SS133
	SWITCHING DIODE 1N4148 or	NDTZ001N4148
	DIODE 1SS176TPA7	1SS176T
D591▲	ZENER DIODE MTZJT-7736B or	QDTB00MTZJ36
▲	ZENER DIODE MTZJT-7736A	QDTA00MTZJ36
D592	ZENER DIODE MTZJT-776.8B	QDTB0MTZJ6R8
D593	ZENER DIODE MTZJT-7720B	QDTB00MTZJ20
D595▲	SWITCHING DIODE 1SS133(T-77) or	QDTZ001SS133
▲	SWITCHING DIODE 1N4148 or	NDTZ001N4148
▲	DIODE 1SS176TPA7	1SS176T
D596▲	SWITCHING DIODE 1SS133(T-77) or	QDTZ001SS133
▲	SWITCHING DIODE 1N4148 or	NDTZ001N4148
▲	DIODE 1SS176TPA7	1SS176T

Ref. No.	Description	Part No.
D597	SWITCHING DIODE 1SS133(T-77) or	QDTZ001SS133
	SWITCHING DIODE 1N4148 or	NDTZ001N4148
	DIODE 1SS176TPA7	1SS176T
D605▲	DIODE 1N5406 or	NDLZ001N5406
▲	DIODE ERC04-06L3	QD4Z0ERC0406
D606▲	DIODE 1N5406 or	NDLZ001N5406
▲	DIODE ERC04-06L3	QD4Z0ERC0406
D607▲	DIODE 1N5406 or	NDLZ001N5406
▲	DIODE ERC04-06L3	QD4Z0ERC0406
D608▲	DIODE 1N5406 or	NDLZ001N5406
▲	DIODE ERC04-06L3	QD4Z0ERC0406
D609	SWITCHING DIODE 1SS133(T-77) or	QDTZ001SS133
	SWITCHING DIODE 1N4148 or	NDTZ001N4148
	DIODE 1SS176TPA7	1SS176T
D611▲	ZENER DIODE MTZJT-7720B	QDTB00MTZJ20
D615▲	SWITCHING DIODE 1N4148 T-77	QDTZ001N4148
D621	ZENER DIODE MTZJT-777.5B	QDTB0MTZJ7R5
D622	SWITCHING DIODE 1SS133(T-77) or	QDTZ001SS133
	SWITCHING DIODE 1N4148 or	NDTZ001N4148
	DIODE 1SS176TPA7	1SS176T
D651▲	FAST RECOVERY DIODE 30DF6 or	QDWZ00030DF6
▲	DIODE ERD29-06J	QD4Z0ERD2906
D652▲	DIODE FR154 or	NDLZ000FR154
▲	FAST RECOVERY DIODE ERB44-02	QDPZ0ERB4402
D653▲	DIODE FR154 or	NDLZ000FR154
▲	FAST RECOVERY DIODE ERB44-02	QDPZ0ERB4402
D654▲	SWITCHING DIODE 1SS133(T-77) or	QDTZ001SS133
▲	SWITCHING DIODE 1N4148 or	NDTZ001N4148
▲	DIODE 1SS176TPA7	1SS176T
D655▲	DIODE FR154 or	NDLZ000FR154
▲	FAST RECOVERY DIODE ERB44-02	QDPZ0ERB4402
D657▲	DIODE 1ZC36	QDQZ0001ZC36
D660	SWITCHING DIODE 1SS133(T-77) or	QDTZ001SS133
	SWITCHING DIODE 1N4148 or	NDTZ001N4148
	DIODE 1SS176TPA7	1SS176T
D661▲	SWITCHING DIODE 1SS133(T-77) or	QDTZ001SS133
▲	SWITCHING DIODE 1N4148 or	NDTZ001N4148
▲	DIODE 1SS176TPA7	1SS176T
D662▲	ZENER DIODE MTZJT-776.8B	QDTB0MTZJ6R8
D666▲	ZENER DIODE MTZJT-7736B or	QDTB00MTZJ36
▲	ZENER DIODE MTZJT-7736A	QDTA00MTZJ36
D671	SWITCHING DIODE 1SS133(T-77) or	QDTZ001SS133
	SWITCHING DIODE 1N4148 or	NDTZ001N4148
	DIODE 1SS176TPA7	1SS176T
D672	SWITCHING DIODE 1SS133(T-77) or	QDTZ001SS133
	SWITCHING DIODE 1N4148 or	NDTZ001N4148
	DIODE 1SS176TPA7	1SS176T
D673	SWITCHING DIODE 1SS133(T-77) or	QDTZ001SS133
	SWITCHING DIODE 1N4148 or	NDTZ001N4148
	DIODE 1SS176TPA7	1SS176T
D692▲	SWITCHING DIODE 1SS133(T-77) or	QDTZ001SS133
▲	SWITCHING DIODE 1N4148 or	NDTZ001N4148
▲	DIODE 1SS176TPA7	1SS176T
D694	PCB JUMPER D0.6-P5.0	JW5.0T
D696	SWITCHING DIODE 1SS133(T-77) or	QDTZ001SS133
	SWITCHING DIODE 1N4148 or	NDTZ001N4148
	DIODE 1SS176TPA7	1SS176T
D811	SWITCHING DIODE 1SS133(T-77) or	QDTZ001SS133
	SWITCHING DIODE 1N4148 or	NDTZ001N4148
	DIODE 1SS176TPA7	1SS176T
D817	SWITCHING DIODE 1SS133(T-77) or	QDTZ001SS133

Ref. No.	Description	Part No.
	SWITCHING DIODE 1N4148 or	NDTZ001N4148
	DIODE 1SS176TPA7	1SS176T
D821	SWITCHING DIODE 1SS133(T-77) or	QDTZ001SS133
	SWITCHING DIODE 1N4148 or	NDTZ001N4148
	DIODE 1SS176TPA7	1SS176T
D826	SWITCHING DIODE 1SS133(T-77) or	QDTZ001SS133
	SWITCHING DIODE 1N4148 or	NDTZ001N4148
	DIODE 1SS176TPA7	1SS176T
D838	ZENER DIODE MTZJT-7710B	QDTB00MTZJ10
D841▲	SWITCHING DIODE 1SS133(T-77) or	QDTZ001SS133
▲	SWITCHING DIODE 1N4148 or	NDTZ001N4148
▲	DIODE 1SS176TPA7	1SS176T
D842▲	ZENER DIODE MTZJT-775.1B	QDTB00MTZJ5R1
D845▲	SWITCHING DIODE 1SS133(T-77) or	QDTZ001SS133
▲	SWITCHING DIODE 1N4148 or	NDTZ001N4148
▲	DIODE 1SS176TPA7	1SS176T
D846▲	SWITCHING DIODE 1SS133(T-77) or	QDTZ001SS133
▲	SWITCHING DIODE 1N4148 or	NDTZ001N4148
▲	DIODE 1SS176TPA7	1SS176T
D847▲	ZENER DIODE MTZJT-775.1B	QDTB00MTZJ5R1
<b>ICS</b>		
IC111▲	IC M37150M8-053FP	QSZAB0SMB088
IC151	IC:MEMORY AT24C01A-10SC or	NSMMA0SAZ011
	IC:(EEPROM) M24C01-MN6 or	NSMMA0SSS027
	IC:MEMORY BR24C01AF-W or	QSMBA0SRM002
	IC:MEMORY S524C20D21	NSZBA0SSM028
IC333▲	IC:CHROMA/IF 1 CHIP M61210FP-R62*	QSZAC0RMB086
IC401	IC:USA STEREO DECODER LA7765	QSZBA0SSY003
IC481	IC:SWITCH TC4053BF(N)	QSMBA0STS002
IC551▲	IC:VERTICAL OUTPUT LA78041 or	QSZBA0SSY006
▲	IC:VERTICAL OUTPUT LA78045	QSZBA0SSY004
IC601▲	PHOTOCOUPLER LTV-817B-F or	NPEB0LTV817F
▲	PHOTOCOUPLER LTV-817C-F	NPEC0LTV817F
IC801	IC:AF POWER AMP LA4285	QSZBA0SSY002
IC802	IC:AF POWER AMP LA4285	QSZBA0SSY002
<b>COILS</b>		
L3	INDUCTOR 18μH-J-26T or	LLAXJATTU180
	INDUCTOR 18μH-K-26T	LLAXKDTKA180
L5	INDUCTOR 22μH-K-5FT or	LLARKBSTU220
	INDUCTOR 22μH-K	LLARKDQKA220
L11	INDUCTOR 0.47μH-J-26T or	LLAXJATTUR47
	INDUCTOR 0.47μH-K-26T	LLAXKDTKAR47
L15	INDUCTOR 1.2μH-J-26T or	LLAXJATTU1R2
	INDUCTOR 1.2μH-K-26T	LLAXKDTKA1R2
L121	INDUCTOR 22μH-K-5FT or	LLARKBSTU220
	INDUCTOR 22μH-K	LLARKDQKA220
L302	CARBON RES. 1/4W J 3.3 Ω or	RCX4JATZ03R3
	CARBON RES. 1/6W J 3.3 Ω	RCX6JATZ03R3
L351	INDUCTOR 100μH-K-5FT or	LLARKBSTU101
	INDUCTOR 100μH-K	LLARKDQKA101
L356	INDUCTOR 10μH-J-26T or	LLAXJATTU100
	INDUCTOR 10μH-K-26T	LLAXKDTKA100
L372	INDUCTOR 15μH-J-26T or	LLAXJATTU150
	INDUCTOR 15μH-K-26T	LLAXKDTKA150
L373	INDUCTOR 8.2μH-J-26T or	LLAXJATTU8R2
	INDUCTOR 8.2μH-K-26T	LLAXKDTKA8R2
L383	CARBON RES. 1/4W J 12 Ω or	RCX4JATZ0120
	CARBON RES. 1/6W J 12 Ω	RCX6JATZ0120
L561▲	LINEARITY COIL STS007 or	LLBD00ZY2002
▲	LINEARITY COIL ELH5L6129N	LLBD00ZMS007

Ref. No.	Description	Part No.
L562▲	LINEARITY COIL ST02LN or	LLBD00ZY2003
▲	CHOKE COIL ELC13B102L	LLC102KMS001
L588	CHOKE COIL 47μH-K or	LLBD00PKV007
	POT COIL 47μH K or	LLBD**DMM001
	POT COIL 47μH K	LLBD00DQE001
L601▲	LINE FILTER JLB2808 or	LLBG00ZXB004
▲	LINE FILTER MS036	LLBG00ZY2009
<b>TRANSISTORS</b>		
Q121	TRANSISTOR 2SC2785(F) or	QGSF02SC2785
	TRANSISTOR 2SC2785(H) or	QQSH02SC2785
	TRANSISTOR 2SC2785(J) or	QQSJ02SC2785
	TRANSISTOR KTC3199(GR) or	NQS10KTC3199
	TRANSISTOR KTC3198(GR) or	NQS40KTC3198
	TRANSISTOR 2SC3331(T)-AANP or	2SC3331TZ
	TRANSISTOR 2SC3331(U)-AANP or	2SC3331UZ
	TRANSISTOR 2SC1815-GR(TPE2)	QQS102SC1815
Q351	TRANSISTOR 2SC2785(F) or	QGSF02SC2785
	TRANSISTOR 2SC2785(H) or	QQSH02SC2785
	TRANSISTOR 2SC2785(J) or	QQSJ02SC2785
	TRANSISTOR KTC3199(GR) or	NQS10KTC3199
	TRANSISTOR KTC3198(GR) or	NQS40KTC3198
	TRANSISTOR 2SC3331(T)-AANP or	2SC3331TZ
	TRANSISTOR 2SC3331(U)-AANP or	2SC3331UZ
	TRANSISTOR 2SC1815-GR(TPE2)	QQS102SC1815
Q377	TRANSISTOR 2SC2785(F) or	QGSF02SC2785
	TRANSISTOR 2SC2785(H) or	QQSH02SC2785
	TRANSISTOR 2SC2785(J) or	QQSJ02SC2785
	TRANSISTOR KTC3199(GR) or	NQS10KTC3199
	TRANSISTOR KTC3198(GR) or	NQS40KTC3198
	TRANSISTOR 2SC3331(T)-AANP or	2SC3331TZ
	TRANSISTOR 2SC3331(U)-AANP or	2SC3331UZ
	TRANSISTOR 2SC1815-GR(TPE2)	QQS102SC1815
Q411	TRANSISTOR 2SA1175(F) or	QGSF02SA1175
	TRANSISTOR KTA1267(GR) or	NQS10KTA1267
	TRANSISTOR KTA1266(GR) or	NQS40KTA1266
	TRANSISTOR 2SA1318(T)-AANP or	2SA1318TZ
	TRANSISTOR 2SA1318(U)-AANP or	2SA1318UZ
	TRANSISTOR 2SA1015-GR(TPE2)	QQS102SA1015
Q441	TRANSISTOR 2SA1175(F) or	QGSF02SA1175
	TRANSISTOR KTA1267(GR) or	NQS10KTA1267
	TRANSISTOR KTA1266(GR) or	NQS40KTA1266
	TRANSISTOR 2SA1318(T)-AANP or	2SA1318TZ
	TRANSISTOR 2SA1318(U)-AANP or	2SA1318UZ
	TRANSISTOR 2SA1015-GR(TPE2)	QQS102SA1015
Q481	TRANSISTOR 2SC2785(F) or	QGSF02SC2785
	TRANSISTOR 2SC2785(H) or	QQSH02SC2785
	TRANSISTOR 2SC2785(J) or	QQSJ02SC2785
	TRANSISTOR KTC3199(GR) or	NQS10KTC3199
	TRANSISTOR KTC3198(GR) or	NQS40KTC3198
	TRANSISTOR 2SC3331(T)-AANP or	2SC3331TZ
	TRANSISTOR 2SC3331(U)-AANP or	2SC3331UZ
	TRANSISTOR 2SC1815-GR(TPE2)	QQS102SC1815
Q531	TRANSISTOR 2SC2785(F) or	QGSF02SC2785
	TRANSISTOR 2SC2785(H) or	QQSH02SC2785
	TRANSISTOR 2SC2785(J) or	QQSJ02SC2785
	TRANSISTOR KTC3199(GR) or	NQS10KTC3199
	TRANSISTOR KTC3198(GR) or	NQS40KTC3198
	TRANSISTOR 2SC3331(T)-AANP or	2SC3331TZ
	TRANSISTOR 2SC3331(U)-AANP or	2SC3331UZ
	TRANSISTOR 2SC1815-GR(TPE2)	QQS102SC1815

Ref. No.	Description	Part No.
Q551	TRANSISTOR 2SA1175(F) or	QQSF02SA1175
	TRANSISTOR KTA1267(GR) or	NQS10KTA1267
	TRANSISTOR KTA1266(GR) or	NQS40KTA1266
	TRANSISTOR 2SA1318(T)-AANP or	2SA1318TZ
	TRANSISTOR 2SA1318(U)-AANP or	2SA1318UZ
	TRANSISTOR 2SA1015-GR(TPE2)	QQS102SA1015
Q552▲	TRANSISTOR 2SD1666R or	QQR02SD1666
▲	TRANSISTOR 2SD1666S or	QQE02SD1666
▲	TRANSISTOR KTD2059(O) or	NQ400KTD2059
▲	TRANSISTOR KTD2059(Y) or	NQ4Y0KTD2059
▲	TRANSISTOR 2SD1825	Q2SD1825****
Q561	TRANSISTOR 2SC2785(F) or	QQSF02SC2785
	TRANSISTOR 2SC2785(H) or	QQSH02SC2785
	TRANSISTOR 2SC2785(J) or	QQSJ02SC2785
	TRANSISTOR KTC3199(GR) or	NQS10KTC3199
	TRANSISTOR KTC3198(GR) or	NQS40KTC3198
	TRANSISTOR 2SC3331(T)-AANP or	2SC3331TZ
	TRANSISTOR 2SC3331(U)-AANP or	2SC3331UZ
	TRANSISTOR 2SC1815-GR(TPE2)	QQS102SC1815
Q571▲	TRANSISTOR 2SD2634	QQZZ02SD2634
Q572	TRANSISTOR 2SC1627Y-TPE2	QQSY02SC1627
Q601▲	FET 2SK3407	QFFZ02SK3407
Q602▲	TRANSISTOR 2SC2120-O-TPE2 or	QQS002SC2120
▲	TRANSISTOR 2SC2120-Y(TPE2)	QQSY02SC2120
Q662▲	TRANSISTOR 2SC2785(F) or	QQSF02SC2785
▲	TRANSISTOR 2SC2785(H) or	QQSH02SC2785
▲	TRANSISTOR 2SC2785(J) or	QQSJ02SC2785
▲	TRANSISTOR KTC3199(GR) or	NQS10KTC3199
▲	TRANSISTOR KTC3198(GR) or	NQS40KTC3198
▲	TRANSISTOR 2SC3331(T)-AANP or	2SC3331TZ
▲	TRANSISTOR 2SC3331(U)-AANP or	2SC3331UZ
▲	TRANSISTOR 2SC1815-GR(TPE2)	QQS102SC1815
Q671▲	TRANSISTOR 2SA1175(F) or	QQSF02SA1175
▲	TRANSISTOR KTA1267(GR) or	NQS10KTA1267
▲	TRANSISTOR KTA1266(GR) or	NQS40KTA1266
▲	TRANSISTOR 2SA1318(T)-AANP or	2SA1318TZ
▲	TRANSISTOR 2SA1318(U)-AANP or	2SA1318UZ
▲	TRANSISTOR 2SA1015-GR(TPE2)	QQS102SA1015
Q675	TRANSISTOR 2SC2785(F) or	QQSF02SC2785
	TRANSISTOR 2SC2785(H) or	QQSH02SC2785
	TRANSISTOR 2SC2785(J) or	QQSJ02SC2785
	TRANSISTOR KTC3199(GR) or	NQS10KTC3199
	TRANSISTOR KTC3198(GR) or	NQS40KTC3198
	TRANSISTOR 2SC3331(T)-AANP or	2SC3331TZ
	TRANSISTOR 2SC3331(U)-AANP or	2SC3331UZ
	TRANSISTOR 2SC1815-GR(TPE2)	QQS102SC1815
Q676	TRANSISTOR 2SC2785(F) or	QQSF02SC2785
	TRANSISTOR 2SC2785(H) or	QQSH02SC2785
	TRANSISTOR 2SC2785(J) or	QQSJ02SC2785
	TRANSISTOR KTC3199(GR) or	NQS10KTC3199
	TRANSISTOR KTC3198(GR) or	NQS40KTC3198
	TRANSISTOR 2SC3331(T)-AANP or	2SC3331TZ
	TRANSISTOR 2SC3331(U)-AANP or	2SC3331UZ
	TRANSISTOR 2SC1815-GR(TPE2)	QQS102SC1815
Q681▲	TRANSISTOR 2SC2120-O-TPE2 or	QQS002SC2120
▲	TRANSISTOR 2SC2120-Y(TPE2) or	QQSY02SC2120
▲	TRANSISTOR KTC3203(Y)	NQSY0KTC3203
Q682▲	TRANSISTOR 2SC2120-O-TPE2 or	QQS002SC2120
▲	TRANSISTOR 2SC2120-Y(TPE2) or	QQSY02SC2120
▲	TRANSISTOR KTC3203(Y)	NQSY0KTC3203
Q683▲	TRANSISTOR 2SC2120-O-TPE2 or	QQS002SC2120

Ref. No.	Description	Part No.
▲	TRANSISTOR 2SC2120-Y(TPE2) or	QQSY02SC2120
▲	TRANSISTOR KTC3203(Y)	NQSY0KTC3203
Q696	RES. BUILT-IN TRANSISTOR BA1F4M-T or	QQSZ00BA1F4M
	RES. BUILT-IN TRANSISTOR KRC103M	NQSZ00KRC103M
Q761	TRANSISTOR 2SC2785(F) or	QQSF02SC2785
	TRANSISTOR 2SC2785(H) or	QQSH02SC2785
	TRANSISTOR 2SC2785(J) or	QQSJ02SC2785
	TRANSISTOR KTC3199(GR) or	NQS10KTC3199
	TRANSISTOR KTC3198(GR) or	NQS40KTC3198
	TRANSISTOR 2SC3331(T)-AANP or	2SC3331TZ
	TRANSISTOR 2SC3331(U)-AANP or	2SC3331UZ
	TRANSISTOR 2SC1815-GR(TPE2)	QQS102SC1815
Q766	TRANSISTOR 2SC2785(F) or	QQSF02SC2785
	TRANSISTOR 2SC2785(H) or	QQSH02SC2785
	TRANSISTOR 2SC2785(J) or	QQSJ02SC2785
	TRANSISTOR KTC3199(GR) or	NQS10KTC3199
	TRANSISTOR KTC3198(GR) or	NQS40KTC3198
	TRANSISTOR 2SC3331(T)-AANP or	2SC3331TZ
	TRANSISTOR 2SC3331(U)-AANP or	2SC3331UZ
	TRANSISTOR 2SC1815-GR(TPE2)	QQS102SC1815
Q771	TRANSISTOR 2SC2785(F) or	QQSF02SC2785
	TRANSISTOR 2SC2785(H) or	QQSH02SC2785
	TRANSISTOR 2SC2785(J) or	QQSJ02SC2785
	TRANSISTOR KTC3199(GR) or	NQS10KTC3199
	TRANSISTOR KTC3198(GR) or	NQS40KTC3198
	TRANSISTOR 2SC3331(T)-AANP or	2SC3331TZ
	TRANSISTOR 2SC3331(U)-AANP or	2SC3331UZ
	TRANSISTOR 2SC1815-GR(TPE2)	QQS102SC1815
Q776	TRANSISTOR 2SC2785(F) or	QQSF02SC2785
	TRANSISTOR 2SC2785(H) or	QQSH02SC2785
	TRANSISTOR 2SC2785(J) or	QQSJ02SC2785
	TRANSISTOR KTC3199(GR) or	NQS10KTC3199
	TRANSISTOR KTC3198(GR) or	NQS40KTC3198
	TRANSISTOR 2SC3331(T)-AANP or	2SC3331TZ
	TRANSISTOR 2SC3331(U)-AANP or	2SC3331UZ
	TRANSISTOR 2SC1815-GR(TPE2)	QQS102SC1815
Q782	TRANSISTOR 2SA1175(F) or	QQSF02SA1175
	TRANSISTOR KTA1267(GR) or	NQS10KTA1267
	TRANSISTOR KTA1266(GR) or	NQS40KTA1266
	TRANSISTOR 2SA1318(T)-AANP or	2SA1318TZ
	TRANSISTOR 2SA1318(U)-AANP or	2SA1318UZ
	TRANSISTOR 2SA1015-GR(TPE2)	QQS102SA1015
Q825	TRANSISTOR 2SC2785(F) or	QQSF02SC2785
	TRANSISTOR 2SC2785(H) or	QQSH02SC2785
	TRANSISTOR 2SC2785(J) or	QQSJ02SC2785
	TRANSISTOR KTC3199(GR) or	NQS10KTC3199
	TRANSISTOR KTC3198(GR) or	NQS40KTC3198
	TRANSISTOR 2SC3331(T)-AANP or	2SC3331TZ
	TRANSISTOR 2SC3331(U)-AANP or	2SC3331UZ
	TRANSISTOR 2SC1815-GR(TPE2)	QQS102SC1815
Q831	TRANSISTOR 2SB892(S) or	QQSS002SB892
	TRANSISTOR 2SB892(T)	QQST002SB892
Q832▲	TRANSISTOR 2SC2785(F) or	QQSF02SC2785
▲	TRANSISTOR 2SC2785(H) or	QQSH02SC2785
▲	TRANSISTOR 2SC2785(J) or	QQSJ02SC2785
▲	TRANSISTOR KTC3199(GR) or	NQS10KTC3199
▲	TRANSISTOR KTC3198(GR) or	NQS40KTC3198
▲	TRANSISTOR 2SC3331(T)-AANP or	2SC3331TZ
▲	TRANSISTOR 2SC3331(U)-AANP or	2SC3331UZ
▲	TRANSISTOR 2SC1815-GR(TPE2)	QQS102SC1815
Q833▲	TRANSISTOR 2SC2785(F) or	QQSF02SC2785

Ref. No.	Description	Part No.
▲	TRANSISTOR 2SC2785(H) or	QQSH02SC2785
▲	TRANSISTOR 2SC2785(J) or	QQSJ02SC2785
▲	TRANSISTOR KTC3199(GR) or	NQS10KTC3199
▲	TRANSISTOR KTC3198(GR) or	NQS40KTC3198
▲	TRANSISTOR 2SC3331(T)-AANP or	2SC3331TZ
▲	TRANSISTOR 2SC3331(U)-AANP or	2SC3331UZ
▲	TRANSISTOR 2SC1815-GR(TPE2)	QQS102SC1815
<b>RESISTORS</b>		
R2	CARBON RES. 1/4W J 100 Ω or	RCX4JATZ0101
	CARBON RES. 1/6W J 100 Ω	RCX6JATZ0101
R3	CARBON RES. 1/4W J 100 Ω or	RCX4JATZ0101
	CARBON RES. 1/6W J 100 Ω	RCX6JATZ0101
R6	PCB JUMPER D0.6-P5.0	JW5.0T
R102	CARBON RES. 1/4W J 2.2k Ω or	RCX4JATZ0222
	CARBON RES. 1/6W J 2.2k Ω	RCX6JATZ0222
R103	CARBON RES. 1/4W J 1.8k Ω or	RCX4JATZ0182
	CARBON RES. 1/6W J 1.8k Ω	RCX6JATZ0182
R104	CARBON RES. 1/4W J 3.3k Ω or	RCX4JATZ0332
	CARBON RES. 1/6W J 3.3k Ω	RCX6JATZ0332
R105	CARBON RES. 1/4W J 4.7k Ω or	RCX4JATZ0472
	CARBON RES. 1/6W J 4.7k Ω	RCX6JATZ0472
R106	CARBON RES. 1/4W J 8.2k Ω or	RCX4JATZ0822
	CARBON RES. 1/6W J 8.2k Ω	RCX6JATZ0822
R107	CARBON RES. 1/4W J 2.2k Ω or	RCX4JATZ0222
	CARBON RES. 1/6W J 2.2k Ω	RCX6JATZ0222
R108	PCB JUMPER D0.6-P5.0	JW5.0T
R109	CARBON RES. 1/4W J 10k Ω or	RCX4JATZ0103
	CARBON RES. 1/6W J 10k Ω	RCX6JATZ0103
R110	CARBON RES. 1/4W J 10k Ω or	RCX4JATZ0103
	CARBON RES. 1/6W J 10k Ω	RCX6JATZ0103
R121	CARBON RES. 1/4W J 100 Ω or	RCX4JATZ0101
	CARBON RES. 1/6W J 100 Ω	RCX6JATZ0101
R123	CARBON RES. 1/4W J 1.2k Ω or	RCX4JATZ0122
	CARBON RES. 1/6W J 1.2k Ω	RCX6JATZ0122
R124	CARBON RES. 1/4W J 4.7k Ω or	RCX4JATZ0472
	CARBON RES. 1/6W J 4.7k Ω	RCX6JATZ0472
R125▲	CARBON RES. 1/4W J 1k Ω or	RCX4JATZ0102
▲	CARBON RES. 1/6W J 1k Ω	RCX6JATZ0102
R126▲	CARBON RES. 1/4W J 220k Ω or	RCX4JATZ0224
▲	CARBON RES. 1/6W J 220k Ω	RCX6JATZ0224
R127▲	CARBON RES. 1/4W J 100k Ω or	RCX4JATZ0104
▲	CARBON RES. 1/6W J 100k Ω	RCX6JATZ0104
R128▲	CARBON RES. 1/4W J 100 Ω or	RCX4JATZ0101
▲	CARBON RES. 1/6W J 100 Ω	RCX6JATZ0101
R129▲	CARBON RES. 1/4W J 22k Ω or	RCX4JATZ0223
▲	CARBON RES. 1/6W J 22k Ω	RCX6JATZ0223
R132▲	PCB JUMPER D0.6-P5.0	JW5.0T
R133	CARBON RES. 1/4W J 22k Ω or	RCX4JATZ0223
	CARBON RES. 1/6W J 22k Ω	RCX6JATZ0223
R151	CARBON RES. 1/4W J 4.7k Ω or	RCX4JATZ0472
	CARBON RES. 1/6W J 4.7k Ω	RCX6JATZ0472
R152	CARBON RES. 1/4W J 4.7k Ω or	RCX4JATZ0472
	CARBON RES. 1/6W J 4.7k Ω	RCX6JATZ0472
R153	CARBON RES. 1/4W J 4.7k Ω or	RCX4JATZ0472
	CARBON RES. 1/6W J 4.7k Ω	RCX6JATZ0472
R155	CARBON RES. 1/4W J 100 Ω or	RCX4JATZ0101
	CARBON RES. 1/6W J 100 Ω	RCX6JATZ0101
R161	CARBON RES. 1/4W J 2.7k Ω or	RCX4JATZ0272
	CARBON RES. 1/6W J 2.7k Ω	RCX6JATZ0272
R162	CARBON RES. 1/4W J 1k Ω or	RCX4JATZ0102

Ref. No.	Description	Part No.
	CARBON RES. 1/6W J 1k Ω	RCX6JATZ0102
R171	CARBON RES. 1/4W J 220 Ω or	RCX4JATZ0221
	CARBON RES. 1/6W J 220 Ω	RCX6JATZ0221
R305	CARBON RES. 1/4W J 1k Ω or	RCX4JATZ0102
	CARBON RES. 1/6W J 1k Ω	RCX6JATZ0102
R306	CARBON RES. 1/4W J 82k Ω or	RCX4JATZ0823
	CARBON RES. 1/6W J 82k Ω	RCX6JATZ0823
R308	CARBON RES. 1/4W J 22k Ω or	RCX4JATZ0223
	CARBON RES. 1/6W J 22k Ω	RCX6JATZ0223
R309	CARBON RES. 1/4W J 6.8k Ω or	RCX4JATZ0682
	CARBON RES. 1/6W J 6.8k Ω	RCX6JATZ0682
R310	CARBON RES. 1/4W J 10k Ω or	RCX4JATZ0103
	CARBON RES. 1/6W J 10k Ω	RCX6JATZ0103
R311	CARBON RES. 1/4W J 1k Ω or	RCX4JATZ0102
	CARBON RES. 1/6W J 1k Ω	RCX6JATZ0102
R314	CARBON RES. 1/4W J 100 Ω or	RCX4JATZ0101
	CARBON RES. 1/6W J 100 Ω	RCX6JATZ0101
R315	CARBON RES. 1/4W J 100 Ω or	RCX4JATZ0101
	CARBON RES. 1/6W J 100 Ω	RCX6JATZ0101
R316	CARBON RES. 1/4W J 100 Ω or	RCX4JATZ0101
	CARBON RES. 1/6W J 100 Ω	RCX6JATZ0101
R317	CARBON RES. 1/4W J 2.2k Ω or	RCX4JATZ0222
	CARBON RES. 1/6W J 2.2k Ω	RCX6JATZ0222
R318	CARBON RES. 1/4W J 2.2k Ω or	RCX4JATZ0222
	CARBON RES. 1/6W J 2.2k Ω	RCX6JATZ0222
R319	CARBON RES. 1/4W J 2.2k Ω or	RCX4JATZ0222
	CARBON RES. 1/6W J 2.2k Ω	RCX6JATZ0222
R322	CARBON RES. 1/4W J 1M Ω or	RCX4JATZ0105
	CARBON RES. 1/6W J 1M Ω	RCX6JATZ0105
R323	CARBON RES. 1/4W J 10k Ω or	RCX4JATZ0103
	CARBON RES. 1/6W J 10k Ω	RCX6JATZ0103
R324	CARBON RES. 1/4W J 100k Ω or	RCX4JATZ0104
	CARBON RES. 1/6W J 100k Ω	RCX6JATZ0104
R329	CARBON RES. 1/4W J 100 Ω or	RCX4JATZ0101
	CARBON RES. 1/6W J 100 Ω	RCX6JATZ0101
R331	CARBON RES. 1/4W J 100 Ω or	RCX4JATZ0101
	CARBON RES. 1/6W J 100 Ω	RCX6JATZ0101
R333	CARBON RES. 1/4W J 10k Ω or	RCX4JATZ0103
	CARBON RES. 1/6W J 10k Ω	RCX6JATZ0103
R336	CARBON RES. 1/4W J 270k Ω or	RCX4JATZ0274
	CARBON RES. 1/6W J 270k Ω	RCX6JATZ0274
R337	CARBON RES. 1/4W J 470 Ω or	RCX4JATZ0471
	CARBON RES. 1/6W J 470 Ω	RCX6JATZ0471
R338	CARBON RES. 1/4W J 220 Ω or	RCX4JATZ0221
	CARBON RES. 1/6W J 220 Ω	RCX6JATZ0221
R339	CARBON RES. 1/4W J 220 Ω or	RCX4JATZ0221
	CARBON RES. 1/6W J 220 Ω	RCX6JATZ0221
R341	CARBON RES. 1/4W J 82k Ω or	RCX4JATZ0823
	CARBON RES. 1/6W J 82k Ω	RCX6JATZ0823
R342	CARBON RES. 1/4W J 150k Ω or	RCX4JATZ0154
	CARBON RES. 1/6W J 150k Ω	RCX6JATZ0154
R343	CARBON RES. 1/4W J 15k Ω or	RCX4JATZ0153
	CARBON RES. 1/6W J 15k Ω	RCX6JATZ0153
R346	CARBON RES. 1/4W J 6.8k Ω or	RCX4JATZ0682
	CARBON RES. 1/6W J 6.8k Ω	RCX6JATZ0682
R348	CARBON RES. 1/4W J 470 Ω or	RCX4JATZ0471
	CARBON RES. 1/6W J 470 Ω	RCX6JATZ0471
R353	PCB JUMPER D0.6-P5.0	JW5.0T
R354	CARBON RES. 1/4W J 2.2k Ω or	RCX4JATZ0222
	CARBON RES. 1/6W J 2.2k Ω	RCX6JATZ0222
R355	CARBON RES. 1/4W J 100 Ω or	RCX4JATZ0101

Ref. No.	Description	Part No.
	CARBON RES. 1/6W J 100 Ω	RCX6JATZ0101
R358	PCB JUMPER D0.6-P5.0	JW5.0T
R373	CARBON RES. 1/4W J 68 Ω or	RCX4JATZ0680
	CARBON RES. 1/6W J 68 Ω	RCX6JATZ0680
R374	CARBON RES. 1/4W J 15k Ω or	RCX4JATZ0153
	CARBON RES. 1/6W J 15k Ω	RCX6JATZ0153
R377	CARBON RES. 1/4W J 270 Ω or	RCX4JATZ0271
	CARBON RES. 1/6W J 270 Ω	RCX6JATZ0271
R378	CARBON RES. 1/4W J 1k Ω or	RCX4JATZ0102
	CARBON RES. 1/6W J 1k Ω	RCX6JATZ0102
R383	CARBON RES. 1/4W J 270 Ω or	RCX4JATZ0271
	CARBON RES. 1/6W J 270 Ω	RCX6JATZ0271
R384	CARBON RES. 1/4W J 220 Ω or	RCX4JATZ0221
	CARBON RES. 1/6W J 220 Ω	RCX6JATZ0221
R391	CARBON RES. 1/4W J 1k Ω or	RCX4JATZ0102
	CARBON RES. 1/6W J 1k Ω	RCX6JATZ0102
R392	CARBON RES. 1/4W J 100 Ω or	RCX4JATZ0101
	CARBON RES. 1/6W J 100 Ω	RCX6JATZ0101
R393	CARBON RES. 1/4W J 100 Ω or	RCX4JATZ0101
	CARBON RES. 1/6W J 100 Ω	RCX6JATZ0101
R394	CARBON RES. 1/4W J 100 Ω or	RCX4JATZ0101
	CARBON RES. 1/6W J 100 Ω	RCX6JATZ0101
R395	PCB JUMPER D0.6-P5.0	JW5.0T
R402	CARBON RES. 1/4W J 5.6k Ω or	RCX4JATZ0562
	CARBON RES. 1/6W J 5.6k Ω	RCX6JATZ0562
R403	PCB JUMPER D0.6-P5.0	JW5.0T
R405	CARBON RES. 1/4W J 3.3k Ω or	RCX4JATZ0332
	CARBON RES. 1/6W J 3.3k Ω	RCX6JATZ0332
R406	CARBON RES. 1/4W J 15k Ω or	RCX4JATZ0153
	CARBON RES. 1/6W J 15k Ω	RCX6JATZ0153
R407	CARBON RES. 1/4W J 6.8k Ω or	RCX4JATZ0682
	CARBON RES. 1/6W J 6.8k Ω	RCX6JATZ0682
R408	CARBON RES. 1/4W J 10k Ω or	RCX4JATZ0103
	CARBON RES. 1/6W J 10k Ω	RCX6JATZ0103
R409	CARBON RES. 1/4W J 10k Ω or	RCX4JATZ0103
	CARBON RES. 1/6W J 10k Ω	RCX6JATZ0103
R412	CARBON RES. 1/4W J 10k Ω or	RCX4JATZ0103
	CARBON RES. 1/6W J 10k Ω	RCX6JATZ0103
R421	CARBON RES. 1/4W J 4.7k Ω or	RCX4JATZ0472
	CARBON RES. 1/6W J 4.7k Ω	RCX6JATZ0472
R422	CARBON RES. 1/4W J 4.7k Ω or	RCX4JATZ0472
	CARBON RES. 1/6W J 4.7k Ω	RCX6JATZ0472
R432	CARBON RES. 1/4W J 220 Ω or	RCX4JATZ0221
	CARBON RES. 1/6W J 220 Ω	RCX6JATZ0221
R435	CARBON RES. 1/4W J 470 Ω or	RCX4JATZ0471
	CARBON RES. 1/6W J 470 Ω	RCX6JATZ0471
R436	CARBON RES. 1/4W J 10k Ω or	RCX4JATZ0103
	CARBON RES. 1/6W J 10k Ω	RCX6JATZ0103
R441	CARBON RES. 1/4W J 10k Ω or	RCX4JATZ0103
	CARBON RES. 1/6W J 10k Ω	RCX6JATZ0103
R442	CARBON RES. 1/4W J 10k Ω or	RCX4JATZ0103
	CARBON RES. 1/6W J 10k Ω	RCX6JATZ0103
R443	CARBON RES. 1/4W J 10k Ω or	RCX4JATZ0103
	CARBON RES. 1/6W J 10k Ω	RCX6JATZ0103
R445	CARBON RES. 1/4W J 10k Ω or	RCX4JATZ0103
	CARBON RES. 1/6W J 10k Ω	RCX6JATZ0103
R481	CARBON RES. 1/4W J 22k Ω or	RCX4JATZ0223
	CARBON RES. 1/6W J 22k Ω	RCX6JATZ0223
R482	CARBON RES. 1/4W J 22k Ω or	RCX4JATZ0223
	CARBON RES. 1/6W J 22k Ω	RCX6JATZ0223
R531	CARBON RES. 1/4W J 22k Ω or	RCX4JATZ0223

Ref. No.	Description	Part No.
	CARBON RES. 1/6W J 22k Ω	RCX6JATZ0223
R532	CARBON RES. 1/4W J 1.8k Ω or	RCX4JATZ0182
	CARBON RES. 1/6W J 1.8k Ω	RCX6JATZ0182
R533	CARBON RES. 1/4W J 3.3 Ω or	RCX4JATZ03R3
	CARBON RES. 1/6W J 3.3 Ω	RCX6JATZ03R3
R535	CARBON RES. 1/4W J 2.2k Ω or	RCX4JATZ0222
	CARBON RES. 1/6W J 2.2k Ω	RCX6JATZ0222
R536	CARBON RES. 1/4W J 470 Ω or	RCX4JATZ0471
	CARBON RES. 1/6W J 470 Ω	RCX6JATZ0471
R537	CARBON RES. 1/4W J 56k Ω or	RCX4JATZ0563
	CARBON RES. 1/6W J 56k Ω	RCX6JATZ0563
R538	CARBON RES. 1/4W J 22k Ω or	RCX4JATZ0223
	CARBON RES. 1/6W J 22k Ω	RCX6JATZ0223
R539	CARBON RES. 1/4W J 4.7k Ω or	RCX4JATZ0472
	CARBON RES. 1/6W J 4.7k Ω	RCX6JATZ0472
R540	CARBON RES. 1/4W J 2.7k Ω or	RCX4JATZ0272
	CARBON RES. 1/6W J 2.7k Ω	RCX6JATZ0272
R541▲	CARBON RES. 1/4W J 2.7k Ω or	RCX4JATZ0272
▲	CARBON RES. 1/6W J 2.7k Ω	RCX6JATZ0272
R542	CARBON RES. 1/4W J 2.7 Ω or	RCX4JATZ02R7
	CARBON RES. 1/6W J 2.7 Ω	RCX6JATZ02R7
R543	CARBON RES. 1/4W J 2.7 Ω or	RCX4JATZ02R7
	CARBON RES. 1/6W J 2.7 Ω	RCX6JATZ02R7
R544	CARBON RES. 1/4W J 2.7 Ω or	RCX4JATZ02R7
	CARBON RES. 1/6W J 2.7 Ω	RCX6JATZ02R7
R549▲	METAL OXIDE FILM RES. 1W J 12 Ω or	RN01120ZU001
▲	METAL OXIDE FILM RES. 1W J 12 Ω	RN01200DP003
R551	METAL OXIDE FILM RES. 2W J 680 Ω or	RN02681ZU001
	METAL OXIDE FILM RES. 2W J 680 Ω	RN02681DP004
R552▲	METAL OXIDE FILM RES. 2W J 8.2 Ω or	RN028R2ZU001
▲	METAL OXIDE FILM RES. 2W J 8.2 Ω	RN028R2DP004
R553	CARBON RES. 1/4W J 2.2k Ω or	RCX4JATZ0222
	CARBON RES. 1/6W J 2.2k Ω	RCX6JATZ0222
R554	CARBON RES. 1/4W J 3.9k Ω or	RCX4JATZ0392
	CARBON RES. 1/6W J 3.9k Ω	RCX6JATZ0392
R555	CARBON RES. 1/4W J 2.2k Ω or	RCX4JATZ0222
	CARBON RES. 1/6W J 2.2k Ω	RCX6JATZ0222
R556	CARBON RES. 1/4W J 47k Ω or	RCX4JATZ0473
	CARBON RES. 1/6W J 47k Ω	RCX6JATZ0473
R557	CARBON RES. 1/4W J 18k Ω or	RCX4JATZ0183
	CARBON RES. 1/6W J 18k Ω	RCX6JATZ0183
R558	CARBON RES. 1/4W J 220 Ω or	RCX4JATZ0221
	CARBON RES. 1/6W J 220 Ω	RCX6JATZ0221
R561	CARBON RES. 1/4W J 1.2k Ω or	RCX4JATZ0122
	CARBON RES. 1/6W J 1.2k Ω	RCX6JATZ0122
R562	CARBON RES. 1/4W J 100k Ω or	RCX4JATZ0104
	CARBON RES. 1/6W J 100k Ω	RCX6JATZ0104
R563	CARBON RES. 1/4W J 10k Ω or	RCX4JATZ0103
	CARBON RES. 1/6W J 10k Ω	RCX6JATZ0103
R564	CARBON RES. 1/4W J 150k Ω or	RCX4JATZ0154
	CARBON RES. 1/6W J 150k Ω	RCX6JATZ0154
R565	CARBON RES. 1/4W J 22k Ω or	RCX4JATZ0223
	CARBON RES. 1/6W J 22k Ω	RCX6JATZ0223
R566	CARBON RES. 1/4W J 8.2k Ω or	RCX4JATZ0822
	CARBON RES. 1/6W J 8.2k Ω	RCX6JATZ0822
R568	CARBON RES. 1/4W J 1k Ω or	RCX4JATZ0102
	CARBON RES. 1/6W J 1k Ω	RCX6JATZ0102
R571	CARBON RES. 1/4W J 680 Ω or	RCX4JATZ0681
	CARBON RES. 1/6W J 680 Ω	RCX6JATZ0681
R572	CARBON RES. 1/4W J 680 Ω or	RCX4JATZ0681
	CARBON RES. 1/6W J 680 Ω	RCX6JATZ0681

Ref. No.	Description	Part No.
R573	CARBON RES. 1/4W J 680 Ω or	RCX4JATZ0681
	CARBON RES. 1/6W J 680 Ω	RCX6JATZ0681
R574	METAL OXIDE FILM RES. 2W J 1k Ω or	RN02102ZU001
	METAL OXIDE FILM RES. 2W J 1k Ω	RN02102DP004
R575	METAL OXIDE FILM RES. 2W J 1k Ω or	RN02102ZU001
	METAL OXIDE FILM RES. 2W J 1k Ω	RN02102DP004
R576	CARBON RES. 1/4W J 2.2k Ω or	RCX4JATZ0222
	CARBON RES. 1/6W J 2.2k Ω	RCX6JATZ0222
R577	CARBON RES. 1/4W J 330 Ω or	RCX4JATZ0331
	CARBON RES. 1/6W J 330 Ω	RCX6JATZ0331
R578▲	CARBON RES. 1/4W J 22 Ω or	RCX4JATZ0220
▲	CARBON RES. 1/6W J 22 Ω	RCX6JATZ0220
R579▲	CARBON RES. 1/4W J 22 Ω or	RCX4JATZ0220
▲	CARBON RES. 1/6W J 22 Ω	RCX6JATZ0220
R581	PCB JUMPER D0.6-P5.0	JW5.0T
R583▲	METAL OXIDE FILM RES. 2W J 6.8 Ω or	RN026R8ZU001
▲	METAL OXIDE FILM RES. 2W J 6.8 Ω	RN026R8DP004
R584▲	CARBON RES. 1/4W J 1k Ω or	RCX4JATZ0102
▲	CARBON RES. 1/6W J 1k Ω	RCX6JATZ0102
R585	CARBON RES. 1/4W J 8.2k Ω or	RCX4JATZ0822
	CARBON RES. 1/6W J 8.2k Ω	RCX6JATZ0822
R586	CARBON RES. 1/4W J 100k Ω or	RCX4JATZ0104
	CARBON RES. 1/6W J 100k Ω	RCX6JATZ0104
R587	CARBON RES. 1/4W J 120k Ω or	RCX4JATZ0124
	CARBON RES. 1/6W J 120k Ω	RCX6JATZ0124
R588▲	CARBON RES. 1/4W J 18k Ω or	RCX4JATZ0183
▲	CARBON RES. 1/6W J 18k Ω	RCX6JATZ0183
R589	CARBON RES. 1/4W J 22k Ω or	RCX4JATZ0223
	CARBON RES. 1/6W J 22k Ω	RCX6JATZ0223
R590	CARBON RES. 1/4W J 12k Ω or	RCX4JATZ0123
	CARBON RES. 1/6W J 12k Ω	RCX6JATZ0123
R591▲	CARBON RES. 1/4W J 220k Ω or	RCX4JATZ0224
▲	CARBON RES. 1/6W J 220k Ω	RCX6JATZ0224
R592▲	CARBON RES. 1/4W J 180k Ω or	RCX4JATZ0184
▲	CARBON RES. 1/6W J 180k Ω	RCX6JATZ0184
R593▲	CARBON RES. 1/4W J 100k Ω or	RCX4JATZ0104
▲	CARBON RES. 1/6W J 100k Ω	RCX6JATZ0104
R594▲	CARBON RES. 1/4W J 68k Ω or	RCX4JATZ0683
▲	CARBON RES. 1/6W J 68k Ω	RCX6JATZ0683
R596▲	METAL OXIDE FILM RES. 1W J 12 Ω or	RN01120ZU001
▲	METAL OXIDE FILM RES. 1W J 12 Ω	RN01200DP003
R597▲	CARBON RES. 1/4W J 6.8k Ω or	RCX4JATZ0682
▲	CARBON RES. 1/6W J 6.8k Ω	RCX6JATZ0682
R598▲	CARBON RES. 1/4W J 47k Ω or	RCX4JATZ0473
▲	CARBON RES. 1/6W J 47k Ω	RCX6JATZ0473
R599▲	CARBON RES. 1/4W J 22k Ω or	RCX4JATZ0223
▲	CARBON RES. 1/6W J 22k Ω	RCX6JATZ0223
R601▲	CEMENT RES. 5W K 0.56 Ω or	RW05R56DP007
▲	CEMENT RES. 5W K 0.56 Ω	RW05R56PG001
R602▲	CARBON RES. 1/4W J 3.3M Ω or	RCX4JATZ0335
▲	CARBON RES. 1/6W J 3.3M Ω	RCX6JATZ0335
R603	CARBON RES. 1/4W J 3.3M Ω or	RCX4JATZ0335
	CARBON RES. 1/6W J 3.3M Ω	RCX6JATZ0335
R604	CARBON RES. 1/4W J 100k Ω or	RCX4JATZ0104
	CARBON RES. 1/6W J 100k Ω	RCX6JATZ0104
R605	CARBON RES. 1/4W J 47 Ω or	RCX4JATZ0470
	CARBON RES. 1/6W J 47 Ω	RCX6JATZ0470
R611	CARBON RES. 1/4W J 220 Ω or	RCX4JATZ0221
	CARBON RES. 1/6W J 220 Ω	RCX6JATZ0221
R612	CARBON RES. 1/4W J 220 Ω or	RCX4JATZ0221
	CARBON RES. 1/6W J 220 Ω	RCX6JATZ0221

Ref. No.	Description	Part No.
R613▲	CEMENT RES. 5W K 0.27 Ω or	RW05R27DP005
▲	CEMENT RESISTOR 5W K 0.27 Ω	RW05R27PG001
R616	CARBON RES. 1/4W J 5.6k Ω or	RCX4JATZ0562
	CARBON RES. 1/6W J 5.6k Ω	RCX6JATZ0562
R617	CARBON RES. 1/4W J 47 Ω or	RCX4JATZ0470
	CARBON RES. 1/6W J 47 Ω	RCX6JATZ0470
R620	CARBON RES. 1/4W J 100 Ω or	RCX4JATZ0101
	CARBON RES. 1/6W J 100 Ω	RCX6JATZ0101
R621	CARBON RES. 1/4W J 1.5k Ω or	RCX4JATZ0152
	CARBON RES. 1/6W J 1.5k Ω	RCX6JATZ0152
R623	CARBON RES. 1/4W J 39 Ω or	RCX4JATZ0390
	CARBON RES. 1/6W J 39 Ω	RCX6JATZ0390
R624	PCB JUMPER D0.6-P5.0	JW5.0T
R626	CARBON RES. 1/4W J 390 Ω or	RCX4JATZ0391
	CARBON RES. 1/6W J 390 Ω	RCX6JATZ0391
R653	CARBON RES. 1/4W J 18k Ω or	RCX4JATZ0183
	CARBON RES. 1/6W J 18k Ω	RCX6JATZ0183
R654▲	CARBON RES. 1/4W J 1.8k Ω or	RCX4JATZ0182
▲	CARBON RES. 1/6W J 1.8k Ω	RCX6JATZ0182
R655▲	CARBON RES. 1/4W J 1k Ω or	RCX4JATZ0102
▲	CARBON RES. 1/6W J 1k Ω	RCX6JATZ0102
R656▲	CARBON RES. 1/4W J 15k Ω or	RCX4JATZ0153
▲	CARBON RES. 1/6W J 15k Ω	RCX6JATZ0153
R657▲	CARBON RES. 1/4W J 15k Ω or	RCX4JATZ0153
▲	CARBON RES. 1/6W J 15k Ω	RCX6JATZ0153
R658	CARBON RES. 1/4W J 470k Ω or	RCX4JATZ0474
	CARBON RES. 1/6W J 470k Ω	RCX6JATZ0474
R660	CARBON RES. 1/4W J 1k Ω or	RCX4JATZ0102
	CARBON RES. 1/6W J 1k Ω	RCX6JATZ0102
R661▲	CARBON RES. 1/4W J 82k Ω or	RCX4JATZ0823
▲	CARBON RES. 1/6W J 82k Ω	RCX6JATZ0823
R662▲	CARBON RES. 1/4W J 82k Ω or	RCX4JATZ0823
▲	CARBON RES. 1/6W J 82k Ω	RCX6JATZ0823
R664▲	CARBON RES. 1/4W J 12k Ω or	RCX4JATZ0123
▲	CARBON RES. 1/6W J 12k Ω	RCX6JATZ0123
R665▲	CARBON RES. 1/4W J 5.6k Ω or	RCX4JATZ0562
▲	CARBON RES. 1/6W J 5.6k Ω	RCX6JATZ0562
R666▲	METAL RESISTOR 2W J 18k Ω or	RN02183ZU001
▲	METAL OXIDE FILM RES. 2W J 18k Ω	RN02183DP004
R667▲	CARBON RES. 1/4W J 27k Ω or	RCX4JATZ0273
▲	CARBON RES. 1/6W J 27k Ω	RCX6JATZ0273
R668▲	CARBON RES. 1/4W J 33k Ω or	RCX4JATZ0333
▲	CARBON RES. 1/6W J 33k Ω	RCX6JATZ0333
R669▲	CARBON RES. 1/4W J 27k Ω or	RCX4JATZ0273
▲	CARBON RES. 1/6W J 27k Ω	RCX6JATZ0273
R670▲	CARBON RES. 1/4W J 100k Ω or	RCX4JATZ0104
▲	CARBON RES. 1/6W J 100k Ω	RCX6JATZ0104
R671	CARBON RES. 1/4W J 3.3k Ω or	RCX4JATZ0332
	CARBON RES. 1/6W J 3.3k Ω	RCX6JATZ0332
R672	CARBON RES. 1/4W J 3.3k Ω or	RCX4JATZ0332
	CARBON RES. 1/6W J 3.3k Ω	RCX6JATZ0332
R673	CARBON RES. 1/4W J 100k Ω or	RCX4JATZ0104
	CARBON RES. 1/6W J 100k Ω	RCX6JATZ0104
R674▲	CARBON RES. 1/4W J 22k Ω or	RCX4JATZ0223
▲	CARBON RES. 1/6W J 22k Ω	RCX6JATZ0223
R676	CARBON RES. 1/4W J 10k Ω or	RCX4JATZ0103
	CARBON RES. 1/6W J 10k Ω	RCX6JATZ0103
R677	CARBON RES. 1/4W J 68k Ω or	RCX4JATZ0683
	CARBON RES. 1/6W J 68k Ω	RCX6JATZ0683
R678	CARBON RES. 1/4W J 47k Ω or	RCX4JATZ0473
	CARBON RES. 1/6W J 47k Ω	RCX6JATZ0473

Ref. No.	Description	Part No.
R681▲	CARBON RES. 1/4W J 12 Ω or	RCX4JATZ0120
▲	CARBON RES. 1/6W J 12 Ω	RCX6JATZ0120
R682▲	METAL OXIDE FILM RES. 1W J 33 Ω or	RN01330ZU001
▲	METAL OXIDE FILM RES. 1W J 33 Ω	RN01330DP003
R683▲	METAL OXIDE FILM RES. 1W J 39 Ω or	RN01390ZU001
▲	METAL OXIDE FILM RES. 1W J 39 Ω	RN01390DP003
R686	CARBON RES. 1/4W J 100 Ω or	RCX4JATZ0101
	CARBON RES. 1/6W J 100 Ω	RCX6JATZ0101
R687	CARBON RES. 1/4W J 10 Ω or	RCX4JATZ0100
	CARBON RES. 1/6W J 10 Ω	RCX6JATZ0100
R690	PCB JUMPER D0.6-P15.0	JW15.0T
R692	CARBON RES. 1/4W J 12k Ω or	RCX4JATZ0123
	CARBON RES. 1/6W J 12k Ω	RCX6JATZ0123
R696▲	CARBON RES. 1/4W J 10 Ω or	RCX4JATZ0100
▲	CARBON RES. 1/6W J 10 Ω	RCX6JATZ0100
R701	CARBON RES. 1/4W J 82 Ω or	RCX4JATZ0820
	CARBON RES. 1/6W J 82 Ω	RCX6JATZ0820
R702	PCB JUMPER D0.6-P5.0	JW5.0T
R703	CARBON RES. 1/4W J 100 Ω or	RCX4JATZ0101
	CARBON RES. 1/6W J 100 Ω	RCX6JATZ0101
R711	CARBON RES. 1/4W J 47k Ω or	RCX4JATZ0473
	CARBON RES. 1/6W J 47k Ω	RCX6JATZ0473
R712	CARBON RES. 1/4W J 3.9k Ω or	RCX4JATZ0392
	CARBON RES. 1/6W J 3.9k Ω	RCX6JATZ0392
R713	CARBON RES. 1/4W J 12k Ω or	RCX4JATZ0123
	CARBON RES. 1/6W J 12k Ω	RCX6JATZ0123
R715	CARBON RES. 1/4W J 22k Ω or	RCX4JATZ0223
	CARBON RES. 1/6W J 22k Ω	RCX6JATZ0223
R721	CARBON RES. 1/4W J 47k Ω or	RCX4JATZ0473
	CARBON RES. 1/6W J 47k Ω	RCX6JATZ0473
R722	CARBON RES. 1/4W J 3.9k Ω or	RCX4JATZ0392
	CARBON RES. 1/6W J 3.9k Ω	RCX6JATZ0392
R723	CARBON RES. 1/4W J 12k Ω or	RCX4JATZ0123
	CARBON RES. 1/6W J 12k Ω	RCX6JATZ0123
R725	CARBON RES. 1/4W J 22k Ω or	RCX4JATZ0223
	CARBON RES. 1/6W J 22k Ω	RCX6JATZ0223
R751	CARBON RES. 1/4W J 75 Ω or	RCX4JATZ0750
	CARBON RES. 1/6W J 75 Ω	RCX6JATZ0750
R752	CARBON RES. 1/4W J 100 Ω or	RCX4JATZ0101
	CARBON RES. 1/6W J 100 Ω	RCX6JATZ0101
R753	CARBON RES. 1/4W J 100 Ω or	RCX4JATZ0101
	CARBON RES. 1/6W J 100 Ω	RCX6JATZ0101
R761	CARBON RES. 1/4W J 820 Ω or	RCX4JATZ0821
	CARBON RES. 1/6W J 820 Ω	RCX6JATZ0821
R762	CARBON RES. 1/4W J 47k Ω or	RCX4JATZ0473
	CARBON RES. 1/6W J 47k Ω	RCX6JATZ0473
R763	CARBON RES. 1/4W J 330 Ω or	RCX4JATZ0331
	CARBON RES. 1/6W J 330 Ω	RCX6JATZ0331
R764	CARBON RES. 1/4W J 10k Ω or	RCX4JATZ0103
	CARBON RES. 1/6W J 10k Ω	RCX6JATZ0103
R766	CARBON RES. 1/4W J 820 Ω or	RCX4JATZ0821
	CARBON RES. 1/6W J 820 Ω	RCX6JATZ0821
R767	CARBON RES. 1/4W J 47k Ω or	RCX4JATZ0473
	CARBON RES. 1/6W J 47k Ω	RCX6JATZ0473
R768	CARBON RES. 1/4W J 330 Ω or	RCX4JATZ0331
	CARBON RES. 1/6W J 330 Ω	RCX6JATZ0331
R769	CARBON RES. 1/4W J 10k Ω or	RCX4JATZ0103
	CARBON RES. 1/6W J 10k Ω	RCX6JATZ0103
R771	CARBON RES. 1/4W J 1k Ω or	RCX4JATZ0102
	CARBON RES. 1/6W J 1k Ω	RCX6JATZ0102
R772	CARBON RES. 1/4W J 100 Ω or	RCX4JATZ0101

Ref. No.	Description	Part No.
	CARBON RES. 1/6W J 100 Ω	RCX6JATZ0101
R776	CARBON RES. 1/4W J 1k Ω or	RCX4JATZ0102
	CARBON RES. 1/6W J 1k Ω	RCX6JATZ0102
R777	CARBON RES. 1/4W J 100 Ω or	RCX4JATZ0101
	CARBON RES. 1/6W J 100 Ω	RCX6JATZ0101
R782	CARBON RES. 1/4W J 330 Ω or	RCX4JATZ0331
	CARBON RES. 1/6W J 330 Ω	RCX6JATZ0331
R801	CARBON RES. 1/2W J 100 Ω or	RCX2JZQZ0101
	CARBON RES. 1/2W J 100 Ω or	RCX2101KA013
	CARBON RES. 1/2W J 100 Ω	RCX2JZPZ0101
R802	CARBON RES. 1/2W J 100 Ω or	RCX2JZQZ0101
	CARBON RES. 1/2W J 100 Ω or	RCX2101KA013
	CARBON RES. 1/2W J 100 Ω	RCX2JZPZ0101
R806	CARBON RES. 1/4W J 100 Ω or	RCX4JATZ0101
	CARBON RES. 1/6W J 100 Ω	RCX6JATZ0101
R807	CARBON RES. 1/4W J 100 Ω or	RCX4JATZ0101
	CARBON RES. 1/6W J 100 Ω	RCX6JATZ0101
R813	CARBON RES. 1/4W J 100 Ω or	RCX4JATZ0101
	CARBON RES. 1/6W J 100 Ω	RCX6JATZ0101
R815	PCB JUMPER D0.6-P5.0	JW5.0T
R817	CARBON RES. 1/4W J 4.7k Ω or	RCX4JATZ0472
	CARBON RES. 1/6W J 4.7k Ω	RCX6JATZ0472
R818	CARBON RES. 1/4W J 82k Ω or	RCX4JATZ0823
	CARBON RES. 1/6W J 82k Ω	RCX6JATZ0823
R823	CARBON RES. 1/4W J 100 Ω or	RCX4JATZ0101
	CARBON RES. 1/6W J 100 Ω	RCX6JATZ0101
R825	CARBON RES. 1/4W J 2.2k Ω or	RCX4JATZ0222
	CARBON RES. 1/6W J 2.2k Ω	RCX6JATZ0222
R826	CARBON RES. 1/4W J 2.2k Ω or	RCX4JATZ0222
	CARBON RES. 1/6W J 2.2k Ω	RCX6JATZ0222
R828	CARBON RES. 1/4W J 10k Ω or	RCX4JATZ0103
	CARBON RES. 1/6W J 10k Ω	RCX6JATZ0103
R831▲	PCB JUMPER D0.6-P5.0	JW5.0T
R832	CARBON RES. 1/4W J 22k Ω or	RCX4JATZ0223
	CARBON RES. 1/6W J 22k Ω	RCX6JATZ0223
R833	CARBON RES. 1/4W J 2.2k Ω or	RCX4JATZ0222
	CARBON RES. 1/6W J 2.2k Ω	RCX6JATZ0222
R834	PCB JUMPER D0.6-P5.0	JW5.0T
R835	CARBON RES. 1/4W J 10k Ω or	RCX4JATZ0103
	CARBON RES. 1/6W J 10k Ω	RCX6JATZ0103
R836	PCB JUMPER D0.6-P15.0	JW15.0T
R837▲	PCB JUMPER D0.6-P5.0	JW5.0T
R838	CARBON RES. 1/4W J 1k Ω or	RCX4JATZ0102
	CARBON RES. 1/6W J 1k Ω	RCX6JATZ0102
R841▲	METAL OXIDE FILM RES. 1W J 5.6 Ω or	RN015R6ZU001
▲	METAL OXIDE FILM RES. 1W J 5.6 Ω	RN015R6DP003
R843▲	CARBON RES. 1/4W J 2.2k Ω or	RCX4JATZ0222
▲	CARBON RES. 1/6W J 2.2k Ω	RCX6JATZ0222
R845▲	CARBON RES. 1/4W J 2.2k Ω or	RCX4JATZ0222
▲	CARBON RES. 1/6W J 2.2k Ω	RCX6JATZ0222
R846▲	CARBON RES. 1/4W J 2.2k Ω or	RCX4JATZ0222
▲	CARBON RES. 1/6W J 2.2k Ω	RCX6JATZ0222
R847▲	METAL OXIDE FILM RES. 1W J 5.6 Ω or	RN015R6ZU001
▲	METAL OXIDE FILM RES. 1W J 5.6 Ω	RN015R6DP003
R848▲	CARBON RES. 1/4W J 2.2k Ω or	RCX4JATZ0222
▲	CARBON RES. 1/6W J 2.2k Ω	RCX6JATZ0222
<b>SWITCHES</b>		
SW101	TACT SWITCH SKQSAB or	SST0101AL038
	TACT SWITCH KSM0612B or	SST0101HH003
	TACT SWITCH SKHHAM	SST0101AL029

Ref. No.	Description	Part No.
SW102	TACT SWITCH SKQSAB or	SST0101AL038
	TACT SWITCH KSM0612B or	SST0101HH003
	TACT SWITCH SKHHAM	SST0101AL029
SW103	TACT SWITCH SKQSAB or	SST0101AL038
	TACT SWITCH KSM0612B or	SST0101HH003
	TACT SWITCH SKHHAM	SST0101AL029
SW104	TACT SWITCH SKQSAB or	SST0101AL038
	TACT SWITCH KSM0612B or	SST0101HH003
	TACT SWITCH SKHHAM	SST0101AL029
SW105	TACT SWITCH SKQSAB or	SST0101AL038
	TACT SWITCH KSM0612B or	SST0101HH003
	TACT SWITCH SKHHAM	SST0101AL029
SW106	TACT SWITCH SKQSAB or	SST0101AL038
	TACT SWITCH KSM0612B or	SST0101HH003
	TACT SWITCH SKHHAM	SST0101AL029
<b>MISCELLANEOUS</b>		
AC601▲	AC CORD LA-2413	WAC0172LW007
B-6	HEAT SINK(PEN)ASSEMBLY L1200UZ	0EM405718
B-7	HEAT SINK(PG)ASS'Y L6200UZ	0EM407070
B-8	HEAT SINK(PG)ASS'Y L6200UZ	0EM407072
BC571	BEAD INDUCTORS FBA04HA600VB-00	LLBF00STU026
BC601	BEAD INDUCTORS FBR07HA121TB-00	LLBF00ZTU021
BC602	PCB JUMPER D0.6-P5.0	JW5.0T
BC603	PCB JUMPER D0.6-P5.0	JW5.0T
BC650	BEAD INDUCTORS FBR07HA121TB-00	LLBF00ZTU021
BC651	BEAD INDUCTORS FBR07HA121TB-00	LLBF00ZTU021
BC652	PCB JUMPER D0.6-P5.0	JW5.0T
BC653	PCB JUMPER D0.6-P5.0	JW5.0T
BC655	PCB JUMPER D0.6-P5.0	JW5.0T
BC691	BEAD INDUCTORS FBR07HA121TB-00	LLBF00ZTU021
BC692	BEAD INDUCTORS FBR07HA121TB-00	LLBF00ZTU021
CF301	4.5M TRAP XT4.5MB2 or	FBE455PLN001
	CERAMIC TRAP 4.5MHz or	FBE455PMR003
	CERAMIC TRAP 4.5MHz	FBE455PMS001
CF302	4.5M FILTER LTH4.5MCB or	FBB455PLN001
	CERAMIC FILTER SFSRA4M50CF00-B0 or	FBB455PMR004
	CERAMIC FILTER 4.5MHz	FBB455PMS001
CLN301	WIRE ASSEMBLY WX1L1200-102	WX1L1200-102
CLN501	WIRE ASSEMBLY WX1L1200-103	WX1L1200-103
F601▲	FUSE 4A/125V 237 TYPE or	PAGJ20CAG402
▲	FUSE STC4A125V U/CT or	PAGE20CW3402
▲	FUSE 4.00A/125V	PAGG20CNG402
FH601	FUSE HOLDER MSF-015 or	XH01Z00LY001
	FUSE HOLDER FH-V-03078 or	XH01Z00DK001
	HOLDER, FUSE CNT41-0014	1790424
FH602	FUSE HOLDER MSF-015 or	XH01Z00LY001
	FUSE HOLDER FH-V-03078 or	XH01Z00DK001
	HOLDER, FUSE CNT41-0014	1790424
GP641▲	GAP. FNR-G3.10D	FAZ000LD6005
JK701	RCA JACK 1P(YELLOW)WITH SWITCH AV1-09S-3 or	JYRL010RP009
	RCA JACK(YELLOW) MTJ-032-06A-20	JYRL010LY013
JK702	RCA JACK 1P(WHITE)WITH SWITCH AV1-09S-4 or	JYRL010RP010
	RCA JACK(WHITE) MTJ-032-06A-22	JYRL010LY015
JK703	RCA JACK 1P(RED)WITH SW ITCH AV1-09S-2 or	JYRL010RP008
	RCA JACK(RED) MTJ-032-06A-21	JYRL010LY014
JK704	RCA JACK 3P (SW) MSP-213-V2-432	JYRL030LY008
JK705	RCA JACK 3P MSP-213-V1-432 PBSN	JXRL030LY048
JK801	HEADPHONE JACK MSJ-035-10A B	JYSL020LY002
JS375	PCB JUMPER D0.6-P5.0	JW5.0T

Ref. No.	Description	Part No.
JS376	PCB JUMPER D0.6-P5.0	JW5.0T
JS481	PCB JUMPER D0.6-P5.0	JW5.0T
JS482	PCB JUMPER D0.6-P5.0	JW5.0T
JS704	PCB JUMPER D0.6-P5.0	JW5.0T
JS831	PCB JUMPER D0.6-P7.5	JW7.5T
L-1	SCREW, B-TIGHT M3X8 BIND HEAD+ or	GBMB3080
	SCREW, B-TIGHT M3X8 BIND HEAD+ or	GBMB3080
	SCREW, B-TIGHT M3X8 BIND HEAD+	GBMB3080
PS691▲	THERMISTOR ZPB45BL7R0A	QNZZ45BL7R0A
RCV101	REMOCON RECEIVE UNIT MIM-93M8DKL or	USESJRSUNT02
	REMOCON RECEIVE UNIT PIC-26042SR-2 or	USESJRSKK032
	REMOCON RECEIVE UNIT PIC-37042SR	USESJRSKK034
RL601▲	POWER RELAY SDT-S-112LMR or	MRNDC12QN014
▲	POWER RELAY RPEF-12-901	MRNDC12KB002
SA601▲	SURGE ABSORBER PVR-07D471KB or	NVQZ07D471KB
▲	SURGE ABSORBER CNR-07D471K or	NVQZR07D471K
▲	SURGE ABSORBER AVR-S07D471KAAS or	QVQZ0AVRS07D
▲	SURGE ABSORBER JVR-07N471K or	NVQZVR07N471
▲	VARIATOR ENC471D-07A	QVQZ0471D07A
SF1	SAW FILTER SAFGM45M7VHGZM0B03	FBB456PMR007
T571▲	FLYBACK TRANS BSC25-2096S or	LTF00CPS2028
▲	FLYBACK TRANS BSC28-0730	LTF00CPP1011
T572	HORIZONTAL DRAIVE TRANS STA5003**	LTH00CPY2003
T601▲	SWICHING TRANS KD-01706 or	LTT00CPKT071
▲	SWITCHING TRANS SA-01114	LTT00CPSA099
TH551	THERMISTOR NRD3503L420Y or	QNWLNRD35034
	THERMISTOR PTN-51F or	QMSZ00PTN51F
	THERMISTOR DC30-4M 503KB	QMVZ304M503K
TP300	PCB JUMPER D0.6-P10.0	JW10.0T
TP301	PCB JUMPER D0.6-P10.0	JW10.0T
TP302	PCB JUMPER D0.6-P10.0	JW10.0T
TP591	PCB JUMPER D0.6-P5.0	JW5.0T
TP592	PCB JUMPER D0.6-P5.0	JW5.0T
TP601	PCB JUMPER D0.6-P7.5	JW7.5T
TU1	TUNER ENV56DB3G3 or	UTUNNTUMS009
	TUNER B8095AP or	UTUNNTUSP018
	TUNER UNIT TEDH9-309A	UTUNNTUAL031
VR561	CARBON P.O.T. 30k Ω B or	VRCB303KA011
	CARBON P.O.T. 30k Ω B	VRCB303HH014
VR562	CARBON P.O.T. 5k Ω B or	VRCB502KA011
	CARBON P.O.T. 5k Ω B	VRCB502HH014
VR661▲	CARBON P.O.T. 30k Ω B or	VRCB303KA011
▲	CARBON P.O.T. 30k Ω B	VRCB303HH014
X344	XTAL 3.579545 MHz or	FXD355LLN003
	XTAL 3.579545MHz(30PPM)	FXD355LCHE01
X441	CERAMIC RESONATOR ZTB378F2 or	FY0374PLN001
	CERAMIC RESONATOR CSB378F2	FY0374PMR001

## CRT CBA

Ref. No.	Description	Part No.
	CRT CBA Consists of the following	-----
<b>CAPACITORS</b>		
C1501	CERAMIC CAP. B K 1000pF/2KV or	CCD3DKD0B102
	CERAMIC CAP. B K 1000pF/2KV or	CCD3DKP0B102
	CERAMIC CAP. 1000pF/2KV	CA3D102PAN04
C1502	ELECTROLYTIC CAP. 47μF/16V M or	CE1CMASL470
	ELECTROLYTIC CAP. 47μF/16V M	CE1CMASDL470
C1511	CERAMIC CAP.(AX) B K 270pF/50V	CCA1JKT0B271
C1521	CERAMIC CAP.(AX) B K 270pF/50V	CCA1JKT0B271



Ref. No.	Description	Part No.
C1531	CERAMIC CAP.(AX) B K 270pF/50V	CCA1JKTOB271
<b>CONNECTOR</b>		
CN1501	PIN CONNECTOR 005P-5100	JTEA001TG001
<b>DIODES</b>		
D1501	DIODE FR104-B or RECTIFIER DIODE ERA22-02 or RECTIFIER DIODE 10ELS2	NDLZ000FR104 QDPZ0ERA2202 QDQZ0010ELS2
<b>COILS</b>		
L1511	PCB JUMPER D0.6-P5.0	JW5.0T
L1521	PCB JUMPER D0.6-P5.0	JW5.0T
L1531	PCB JUMPER D0.6-P5.0	JW5.0T
<b>TRANSISTORS</b>		
Q1512	TRANSISTOR KTC3503Y or TRANSISTOR 2SC3619	NQWY0KTC3503 QQ9Z02SC3619
Q1522	TRANSISTOR KTC3503Y or TRANSISTOR 2SC3619	NQWY0KTC3503 QQ9Z02SC3619
Q1532	TRANSISTOR KTC3503Y or TRANSISTOR 2SC3619	NQWY0KTC3503 QQ9Z02SC3619
<b>RESISTORS</b>		
R1510▲	FIXED METAL OXIDE FILM RES. 3W J 10k Ω or ▲ METAL RESISTOR 3W J 10k Ω or ▲ METAL RES. 3W J 10k Ω or ▲ FIXED METAL OXIDE FILM RES. 3W J 10k Ω	RN03103KE008 RN03103ZU001 RN03103UB503 RN03103DP005
R1511	CARBON RES. 1/4W J 1.5k Ω or CARBON RES. 1/6W J 1.5k Ω	RCX4JATZ0152 RCX6JATZ0152
R1512	CARBON RES. 1/4W J 1.5k Ω or CARBON RES. 1/6W J 1.5k Ω	RCX4JATZ0152 RCX6JATZ0152
R1515	CARBON RES. 1/4W J 2.7k Ω or CARBON RES. 1/6W J 2.7k Ω	RCX4JATZ0272 RCX6JATZ0272
R1516	PCB JUMPER D0.6-P5.0	JW5.0T
R1518	CARBON RES. 1/4W J 330 Ω or CARBON RES. 1/6W J 330 Ω	RCX4JATZ0331 RCX6JATZ0331
R1519	CARBON RES. 1/4W J 100 Ω or CARBON RES. 1/6W J 100 Ω	RCX4JATZ0101 RCX6JATZ0101
R1520▲	FIXED METAL OXIDE FILM RES. 3W J 10k Ω or ▲ METAL RESISTOR 3W J 10k Ω or ▲ METAL RES. 3W J 10k Ω or ▲ FIXED METAL OXIDE FILM RES. 3W J 10k Ω	RN03103KE008 RN03103ZU001 RN03103UB503 RN03103DP005
R1521	CARBON RES. 1/4W J 1.5k Ω or CARBON RES. 1/6W J 1.5k Ω	RCX4JATZ0152 RCX6JATZ0152
R1522	CARBON RES. 1/4W J 1.5k Ω or CARBON RES. 1/6W J 1.5k Ω	RCX4JATZ0152 RCX6JATZ0152
R1525	CARBON RES. 1/4W J 2.7k Ω or CARBON RES. 1/6W J 2.7k Ω	RCX4JATZ0272 RCX6JATZ0272
R1526	PCB JUMPER D0.6-P5.0	JW5.0T
R1528	CARBON RES. 1/4W J 330 Ω or CARBON RES. 1/6W J 330 Ω	RCX4JATZ0331 RCX6JATZ0331
R1529	CARBON RES. 1/4W J 100 Ω or CARBON RES. 1/6W J 100 Ω	RCX4JATZ0101 RCX6JATZ0101
R1530▲	FIXED METAL OXIDE FILM RES. 3W J 10k Ω or ▲ METAL RESISTOR 3W J 10k Ω or ▲ METAL RES. 3W J 10k Ω or ▲ FIXED METAL OXIDE FILM RES. 3W J 10k Ω	RN03103KE008 RN03103ZU001 RN03103UB503 RN03103DP005
R1531	CARBON RES. 1/4W J 1.5k Ω or CARBON RES. 1/6W J 1.5k Ω	RCX4JATZ0152 RCX6JATZ0152
R1532	CARBON RES. 1/4W J 1.5k Ω or CARBON RES. 1/6W J 1.5k Ω	RCX4JATZ0152 RCX6JATZ0152
R1535	CARBON RES. 1/4W J 2.7k Ω or CARBON RES. 1/6W J 2.7k Ω	RCX4JATZ0272 RCX6JATZ0272
R1536	PCB JUMPER D0.6-P5.0	JW5.0T

Ref. No.	Description	Part No.
R1538	CARBON RES. 1/4W J 330 Ω or CARBON RES. 1/6W J 330 Ω	RCX4JATZ0331 RCX6JATZ0331
R1539	CARBON RES. 1/4W J 100 Ω or CARBON RES. 1/6W J 100 Ω	RCX4JATZ0101 RCX6JATZ0101
R1541	PCB JUMPER D0.6-P5.0	JW5.0T
R1542	PCB JUMPER D0.6-P5.0	JW5.0T
R1543	PCB JUMPER D0.6-P5.0	JW5.0T
<b>MISCELLANEOUS</b>		
JK1501▲	CRT SOCKET ISHS40ST or ▲ CRT SOCKET HPS0521-012212	JSCC290PK006 JSCC290HD012
JS1501	PCB JUMPER D0.6-P7.5	JW7.5T
TP1501	PCB JUMPER D0.6-P7.5	JW7.5T
TP1502	PCB JUMPER D0.6-P10.0	JW10.0T

